

MINISTRY OF EDUCATION AND SCIENCE OF UKRAINE

**O. M. BEKETOV NATIONAL UNIVERSITY
of URBAN ECONOMY in KHARKIV**

Methodological recommendations
for the implementation of the course project
and self-dependent work
on the subject

**“ARCHITECTURE of BUILDINGS and
CONSTRUCTIONS”**

*(for the second year full-time students
the first (bachelor) level of high education
specialty 192 – Construction and civil engineering)*

**Kharkiv
O. M. Beketov NUUE
2021**

Methodological recommendations for the implementation of course project and self-dependent work on the subject «Architecture of buildings and constructions » (for the second year full-time students the first (bachelor) of high education level the specialty 192 Construction and civil engineering) / O. M. Beketov National University of Urban Economy in Kharkiv; com. : N. V. Moroz, A. O. Garbuz. – Kharkiv : O. M. Beketov NUUE, 2021. – 31 p.

Compiler: N. V. Moroz
A. O. Garbuz

Reviewer senior lecturer T. N. Apatenko

Recommended by the department of urban planning, record № 5 on 09.02.2021.

CONTENTS

INTRODUCTION.....	4
1 GENERAL DESIGN BASIS OF RESIDENTIAL BUILDINGS	5
2 CONTENTS AND GRAPHICAL FORMATION OF THE COURSE PROJECT	6
3 DEVELOPMENT OF CALCULATION AND GRAPHIC PART OF THE COURSE PROJECT	7
3.1 Familiarization with the general recommendations of the design of residential buildings	7
3.2 Execution of the general planning drawing of a two-section residential building	12
3.3 Technical and economic indicators of the residential buildings	20
REFERENCES	23
APPENDIX A	24
APPENDIX B	28
APPENDIX C	29

INTRODUCTION

Multi-apartment buildings are still developing high rate. Cities need a lot of new contemporary apartment houses. Design of residential buildings is a very complicated work. After all, you need to take into account not only the convenience of a large number of residents, and to design a home in such a way, that it was stable, had all the necessary life support systems. In the design of multi-apartment buildings take into account not only the construction norms, but also requirements of sanitary.

During the project works of multi-apartment building they solves problems of insolation (illumination) of accommodations, it is assumed ventilation of the building, its systems of thermal protection. Last times buildings build, the exterior walls of which are warmed by special materials to avoid excessive heat loss. In the design process of an apartment building must necessarily be taken climatic conditions of the region, seismological features.

During the design of multi-storey buildings are not taken only the quality and properties of building and finishing materials, as well as requirements of environmental and sanitary regulations, energy efficiency and exterior of the building. It is also necessary to take into account the perspectives for the development of the district, where the house built.

The requirements of the functionality and convenience of the building play not a small role in the design of residential buildings. The designer has to think ways to save heat, electricity, water and other resources.

The building should fit into the surrounding architectural landscape organically, and do not break the aesthetic exterior of the surrounding buildings. Contemporary building and decoration materials will help the new house harmoniously fit into the surrounding landscape.

1 GENERAL DESIGN BASIS OF RESIDENTIAL BUILDINGS

The construction of buildings is carried out according to the projects. The project is a set of technical documents which characterizing the building planned for construction.

Projects are model and individual.

A model design is intended to be reusable in construction. It takes into account all design, operational, 3D-planning, economic requirements, natural and climatic conditions. When a model project is applied, a binding draft is developed. During the drawing process, drawings are corrected. It correctes the structure of the foundations taking into account engineering and geological research, the construction area, hydrological conditions.

An individual project is for unique, complex buildings construction. The initial document for the start of design is a design task, which is prepared by the customer together with the design organization. The task contains the necessary information about the purpose of the building, its dimensions, the construction area, the geo-plan of the site, the structures used, the materials they are made from, and the design terms.

Design can be carried out in two or one stage.

Single-stage design is used for buildings with a simple technical solution and when linking model projects. Based on the design assignment, a detailed design with a summary estimate is made. The working project is combined with the working documentation, it includes all the necessary design materials.

Two-stage design is carried out for the preparation of model designs and individual complex buildings. At the first stage, a project with a summary estimate is developed. It serves to review and evaluate the architectural and constructive solutions of the building, making solutions on its approval. During the design process, several building solutions can be developed.

At the second stage, on the basis of the approved project, working documentation with estimates is developed. The documentation includes sets of working drawings, detailed cost estimates, drawings of units and parts, landscaping, engineering preparation of the territory.

Buildings are designed according to modular coordination Construction Dimensions (ICDC). The ICDC is a set of rules for the coordination of sizes of large-scale planning solutions and structural elements of building products and equipment based on a module.

2 CONTENTS AND GRAPHICAL FORMATION OF THE COURSE PROJECT

The successive course project depends on the availability of the necessary theoretical knowledge, as well as the right order to work and correct execution of tasks.

Methodological guidelines should be used with the lectures materials and educational and reference books.

In the process, of a theoretical part studying on each task a student must review the general recommendations and requirements to structure, and also to understand the ways and methods of these requirements use. It will allow a student to approach consciously to building a new one and evaluate the existing design, as well as apply their own knowledge taken during the analysis of one or another building.

The course project is executed in a pencil on drawing paper format A4 or A3, or electronically in case of the program AUTOCAD application. Each sheet is to be drawn with a frame of the fields to the left – 20 mm, and with other sides – 5 mm and a stamp in accordance with the regulations. After finishing the drawings of the above formats, they are sewn into an album with the main writing on the title page and hand in to the teacher. The drawings are attached with a recommendation adopted and short information of constructive elements.

The course project is executed in accordance with the variant of the task (Appendix A, B), corresponding to the last number of the Student's Credit Book.

Drawings of the course project are executed in sheets of A3 format, or A4 ones, when the following drawings are located:

- Plans for the ground and typical floors scale 1: 100
- Front elevation scale 1: 100;
- Vertical section of the building (with the display of internal stairs) scale 1: 100;

- Plans of foundations, floors scale 1:100;
- Roof plan scale 1: 100;
- Two-three constructive joints of the building scale 1: 10 or 1: 20.

Recommendations adopted are added to the graphic part of the design, which consists of the following sections:

- the structural scheme of the building and the constructive decisions of the separate elements;
- description of foundations and their constructive decisions;
- description of the constructions of all elements of the building;
- exterior and interior design of the building;
- technical and economic indicators of the design;
- references.

3 DEVELOPMENT OF CALCULATION AND GRAPHIC PART OF THE COURSE PROJECT

3.1 Familiarization with the general recommendations of the design of residential buildings

In the process of carrying out the task, pay attention to the questions:

- general requirements for residential buildings;
- evacuation requirements, standards for designing evacuation ways (doors, corridors, stairs);
- sanitary-hygienic requirements and regulations of their norms of a residential apartment;
- types of apartments, design features of separate residential and secondary rooms.

The 3D-planning *structure of the building* is called the system of combining the main and auxiliary rooms of selected sizes and shapes into a single integral composition.

Based on the location of the premises, several space-planning systems of buildings are distinguished.

BUILDING DRAWING

Plan. Plan of building represents a horizontal section of building at given height seen from top. It is a general conventional to imagine that the building has been cut down by a horizontal plane at the sill level of the window and is seen from the top after removal of so cutpart. The plan shows the arrangement of rooms, varandah or corridor, position of door, and window and other openings along with their respective sizes.

The dimension of the room indicated as Breadth \times Length. In the case of Varandah's, the given dimension upto the end of Varandah retaining wall and the position of beams, sunshades, portico, ventilators which are above sill level of window are shown with dotted or broken lines.

Line diagram is the sketch generally not drawn to particular scale also known as line sketch. The relative positions of all elements like rooms, doors, windows are clearly shown inside to inside. From the given specifications, the thickness of wall in super structure shall be taken to draw the fully dimensioned plan to a convenient scale.

Floor plan, first, grid lines (the coordinate axes) are marked in capital letters, – horizontally to the left and to the right and the figures vertically –, from the bottom upwards. After that, in accordance with the variants of structural elements binding, the exterior and interior walls are drawn. The main dimensions are taken by multiple enlarged modules of 300 mm, 600 mm, in accordance with the modular size coordination in construction. The construction of bearing walls should be made from materials specified in the task. Their thickness is taken on the basis of heat engineering calculations and for constructive reasons.

Horizontal section for the plan is taken at the level of the middle of the window, which allows to show the width of window and door openings and the size of the walls.

The interior bearing walls, as well as the walls of staircases, are made from bricks or from large blocks – depending on the task.

Partitions are made from bricks 65 mm and 120 mm thick, lightweight concrete blocks, gypsum concrete panels thickness 80 mm; interroom walls – from bricks of 250 mm thickness or from gipsoconcrete slabs with an air hole of 40 mm, the total thickness of such a partition – 200 mm.

In staircase designing, staircase runs (their width in residential buildings – 1 050 mm or 1 200 mm) with space between them from 100 mm to 400 mm, the stairs with a cut in the place of its section and conventional desing of the staircase run lifting direction. The cross sections of the stairs in the plans are mutually brought within their refinement in the cross section of the house.

The plans show equipment in accordance with the regulations of the planning elements of residential buildings.

Section. The sectional view is drawn on the top right side of drawing sheet. The view shall be started from starting point of the section line and the horizontal dimensions along the section are represented in sequence in developing the sectional elevation The section of walls from bottom to top, position of doors, windows that are viewed shall be drawn. From the given specifications, the foundation details, flooring details, roofing details are neatly drawn and such information is to be mentioned in the section. But the different materials used in the construction shall be indicated by drawing the respective conventional signs.

Stair case and their constructive elements. The calculation of the staircase is done according to the use of the construction. So, for residential buildings, the pitch of a staircase run should be expressed in a ratio of 1:2. Then, the **tread** (size of steps) is determined. If the **rise** of one of them is equal to 15 cm, then the width should be at least 30 cm, respectively, the higher the staircase is located on the stairs, the wider it should be. It should be remembered the best option is to create run with even number of tread, but this number should not exceed 16. In order to calculate whether you need a staircase, you need to divide the height of the stair to a height that is equal to one tread.

Virtical Elevation or front view is the outward view of a completed building along any side of the building. When a building is seen by standing in front of it, the view is known as front elevation. Similarly backside view is called rear elevation or from any side of it which is known as side elevation.

Building elevations – show exterior materials, roof pitches, balconys, chimney termination, and attic ventilation.

To design the elevations corresponding to a design plan, much done before the process of working on a plan and section. Because they depend on the elevation of buildings, the location of premises near the front wall, the choice of the size of windows and piers in a certain order interconnected and reflected on the elevation.

All parts of the elevation, cornices, balconies, entrance doors, window sashes, etc. are necessary.

On the elevation, it's also shown all the technical devices which go to the roof - pipes, hearing windows.

On the elevation drawings it is necessary to show the vertical axes of the side walls and on one side – marks of the levels of the ground, the top of the plint, the bottom and the top of the window openings, the top of the cornice and roof.

The main and side elevations of a residential building graphically developed (scale 1: 100).

Foundations. In accordance with the 3D design scheme of the building to determine the bearing walls, under which it is need to design the foundations. The material of the foundations must be agreed with the teacher. If the foundation is made of prefabricated reinforced concrete, on the plan of foundations it is necessary to designate the type of applied foundation blocks and bases.

The plane of the foundations depicts the contours and dimensions of the walls foundations with the corresponding bindings to the axes of the building, foundation depth. Depth of foundations is taken depending on the type of soil, construction area, the depth of the soil freezing, natural conditions, presence of the building basement. Conditionally take in soils of medium strength with low levels of groundwater.

Floor slabs plan. Slab is a structural element, made of concrete, used to create flat horizontal surfaces such as floors, roof decks and ceilings. A slab is generally several centimetres thick and supported by beams, columns, walls, or the ground.

Concrete slabs can be prefabricated off-site and lowered into place or may be poured in-situ using formwork. If reinforcement is required, slabs can be pre-stressed or the concrete can be poured over rebar positioned within the formwork.

On the floor plan, it is necessary to denote the fixing and anchoring of the floors elements, to denote the dimensions, which determine the applied structures. On the floors plan to denote runs, staircases and ventilation channels

Roof top plan. Roofs protect the building structure and the inhabitants from adverse atmospheric and exposure condition and also to enable privacy to its inhabitants. The design and construction of a roof necessitate of design factors which, the element of drainage holds the most crucial role. There are classified into two categories – Flat Roofs and Pitched (Sloping) Roofs.

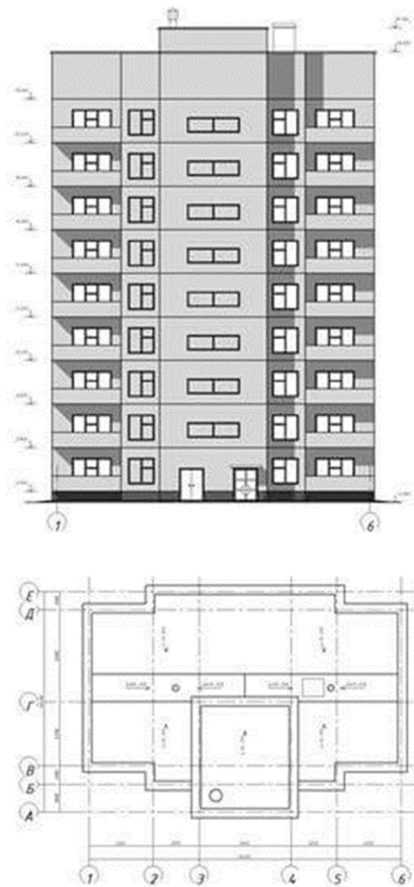

Figure 1 – Flat Roof

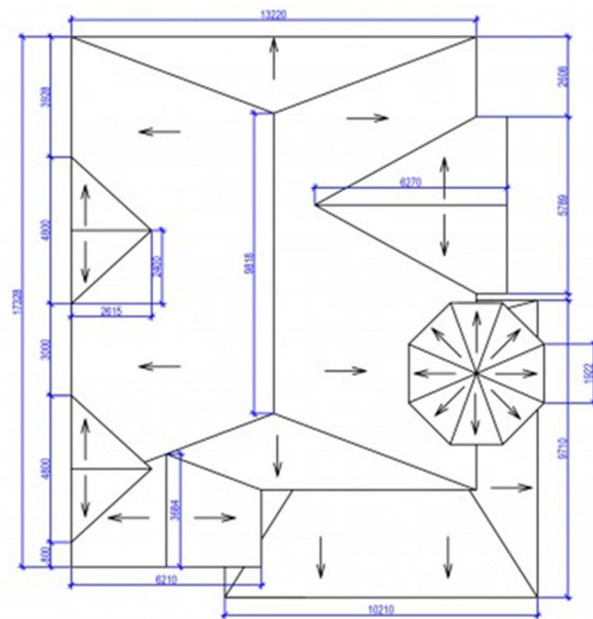

Figure 2 – Double Pitched Roof

The flat roof has none or only very slight roof pitches (Figure 1). When planning a flat roof an incline of minimum 2 % should be considered (which is 1,15°) in order to be able to drain off rain water or melt water. The low owned weight and the extended

usage possibilities (e.g. for roof terraces) are aside from the cost effective production the most important advantages of a flat roof. The construction of a flat roof can either be constructed as a cold roof (single-shell roof) or as a warm roof (double-shell roof).

Pitched Roofs are the roofs, which generally slopes downwards in one, two or more parts (depending upon the design), at a certain angle from the central ridge (the central ridge is the highest point or peak in a sloping roof).

A roof plan is a scaled drawing or diagram of a proposed roof development containing dimensions of the entire roof structure, including shape, size, design and placement of all materials, ventilation, drainage, slopes, valleys and more.

3.2 Execution of the general planning drawing of a three-floors residential building

Drawing floor plans of residential building at levels.

The drawing of a three-dimensional planning solution of a residential building is carried out taking into account the various requirements: functional, physical-technical, constructive, architectural and economic. At the same time there should be taken into the account: the number of apartments in the section; kind of apartments; the mutual planning of separate premises relative to each other and with the respect to the rooms of neighboring apartments; functional zoning of the apartment; design scheme of the building; the size of the steps and runs, the material bearing and enclosure structures.

When designing apartments, special attention should be paid to its functional zoning, providing functional connections between separate rooms and groups of the ones. The apartment should have the following functional areas: entrance hall, working room (kitchen), living room for family rest, bedroom, sanitary hygiene (WC, bathroom), secondary (fitted wardrobes, storerooms).

The living room and the kitchen should be directly connected to the entrance hall. Bedrooms should be impassable and located near the bathroom. It is allowed to enter the bedroom through the living room, but such decision is undesirable. Additional connection of the living room with the kitchen is allowed in the case of kitchen

furnishings with an electric stove, with the kitchen having a second entrance with a hall or corridor.

Types of apartments in the number of residential rooms and their area in residential buildings II category should be taken for table 1.

Table 1 – Types of apartments and their area depending on the number of living rooms

	The number of habitat rooms				
	1	2	3	4	5
The lower and upper limits of the apartments area, m ²	30-40	48-58	60-70	74-85	92-98

Note. In order to unify the design and planning decisions of residential buildings it is allowed to increase the area of individual types of apartments by 5 %.

The area of the living room in a one-room apartment should be not less than 15 m², in other apartments - not less than 17 m². The minimum area of a bedroom for one person – 10 m², for two – 14 m². The total area of the kitchen in one-room apartment – 7 m², in two - and more room – 8 m². The minimum area of the study room is 10 m².

Residential rooms in the apartments of II category can not be passable, except for four- and five-room, where through the common room can be provide entrance to one of the bedrooms or a study room.

The width of the secondary premises of the apartments should be not less: kitchen – 1,8 m, utility (hall) – 1,5 m, corridors leading to living rooms – 1,1 m.

The height of residential apartments from floor to floor should be not less than 2,8 m. The height of residential apartments from floor to ceiling – not less than 2,5 m. In areas with an average monthly temperature in July 21°C and higher the height of residential apartments should be taken not less than 3,0 m, and the height of residential apartments – not less than 2,7 m. The height of utilities corridors, bathrooms and other secondary rooms can be reduced to 2,1 m.

The location of windows and doors in each room should facilitate the comfortable furnituring and good illumination. The ratio of the area of window openings of living rooms and kitchens to the floor area of these apartments should be no more than 1: 5 and not less than 1: 8.

It is worth focus on the direction of the door opening. Exterior doors of the house should be opened only outside, entering the apartment from the staircase inside the apartment, the door of the bathroom – only outside. The doors of the living rooms can be opened both inside the room and into the corridor or hall, but so that it could be comfortable.

The constructive solution of the building must match the following technical requirements: strength, durability, endurance, fire safety, and industrial, economical.

The material and structure of the walls are given in variants (*Appendix B, C*). The final thickness of the exterior walls is determined for a climate of construction area, in accordance with the heat engineering calculation. The thickness of the interior walls is taken for constructive reasons, i.e., provided that the structures of the ceilings can be leveled against them, the presence of ventilation channels in them, etc. The thickness of the partitions wall is taken depending on the material which they are made from. Inter-apartment partitions are double.

Kitchens and bathrooms should be provided with ventilation channels located in the interior bearing walls, in one channel of 14 cm × 14 cm from each room (it is allowed to combine the ventilation channels of the bath and toilet with one size of 14 cm × 27 cm).

It is necessary to design a building with the simultaneous development of drawings of floor plans, sections and elevations, which allows to reconcile separate elements of the house.

Drawing Vertical Section of residential building: Develop cross-section and building sections of a residential building and draw the entrance area of the first floor of the section. To design a graphic building section of a residential building in the place of the staircase and the window opening (scale 1: 100).

Perform such requirements and recommendations:

– first define the cut line on plans. It should cut the building in the most complicated places and pass through a window and door openings in the walls and partitions. These structures should be carefully designed, despite the small scale. It is

necessary to show the construction of stairs, rafters, supported constructions of floors and coverings, roofs;

- on the cut of building sections the axes of the walls binding and the dimensions line of the building height must always be show;

- level of the ground floor is $\pm 0,00$. All levels above zero are positive; below – negative;

- the development of building sections begins with the construction of its scheme, i.e., they draw a ground line, the axis of the walls, which intersects the section, and draw the walls of the corresponding thickness on them, they draw the lines of floors level, denote the thickness of the floor. In the scheme of the building section, first, the staircase are developed. For that, there are floor lines of the inter-floor landing and two vertical lines bounding the width of the landings and providing the nubur a breakdown of treads;

- for the floor design in the drawing of the building section it is necessary to show the flatness of the slabs, the structure of the floor;

- roof height is determined on the type of roof used. To drawing the full height it is necessary to take into account the eave.

Drawing Stair case. The calculation is performed on a separate sheet of A-4 format with the drawing of the stair case plan.

If the stairs should be 4,500 cm, then the number of treads of a given height is 30 pieces ($4,500 : 150$). Since 30 is more than 16, then you will need two runs connected by a staircase. This value should be divided into two, which results in 15 treads on each run. But there will be fewer treads, as one of each run will go to the landing.

Since the width of the tread is 30 cm, the width of the run will be $140 \text{ mm} \times 300 \text{ mm}$ (14 treads per run), 4 200 mm. In order to calculate the width of the staircase (this is enough, since it should be equilateral), you need to divide the value in two.

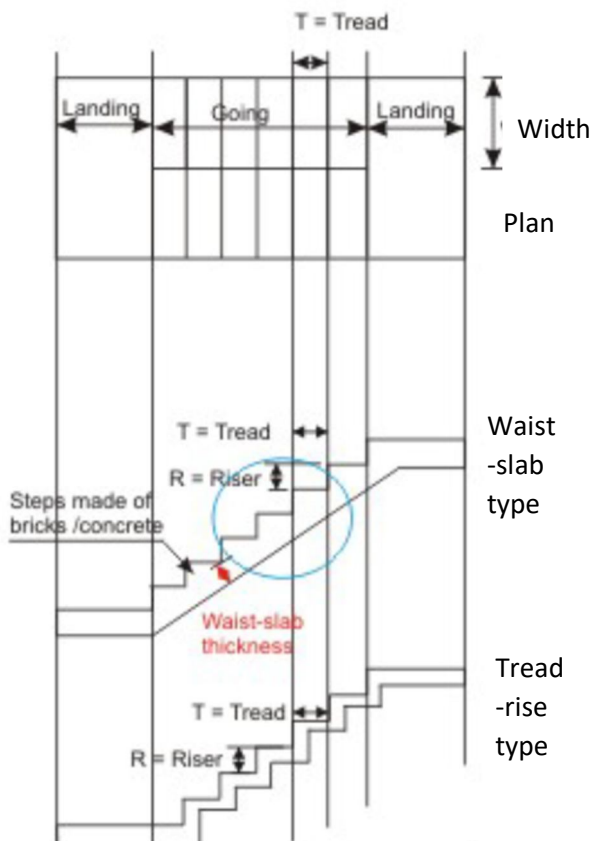

Figure 3 – Typical flight

In such a width and length of the staircase will be 2 100 mm. Its area will be equal to 4,41 m². This result is the most desirable in terms of the requirements of the DBN, these dimensions are considered safe for the implementation of life processes, as well as for the evacuation of the inhabitants of the house through fire, earthquake and any other natural disaster.

Drawing Vertical Elevation of residential building.

On the drawings of the elevations show all the elements of the building from the side of the facade, namely: basement, walls, windows, doors, roof, pipes, antennas, stairs, downpipes, etc. All of these elements are drawn according to the dimensions defined in the plans and cross sections. All elevation elements must comply with standard conventions. On the elevations of buildings with walls made of prefabricated elements (large blocks, panels, etc.), walls are cut into panels or blocks. Windows and doors openings and gates with a drawing scale of 1: 100 and larger should be indicated by a stroke with two thin lines. At smaller scales, only the contours of the sashes and openings are drawn. Hatching distinguishes separate sections of walls, the material of which differs from the main finishing material. Complex sections of the elevation are performed as a single fragment on a larger scale. On the fragments of the elevation show all the details, put the necessary marks and legends.

On the elevation of the building is indicated:

- marks the lower and top openings of windows, doors, gates, as well as the top of the plinth, roof, pipes, stairs and other;
- finishing the plinth, the walls of the roof;
- shadows from parts of the building;
- building axis;
- window markings;
- ground and blind area level.

The marks of the parts of the building are indicated by an arrow with a shelf turned towards the image. Marks are placed in one or more columns vertically. Some marks may appear outside the columns. On the drawing of the facade indicate the marks, sizes and bindings of openings and holes not indicated on the plans. An example of the facade of the building is presented in Figure A4.

The coordination axes of the building are indicated in the places: along the edges of the elevation; in places of “ledges” of walls according to the building plan; at expansion joints.

In the lower part of the elevation, the ground level shown with a thick line, and the top of the blind area with a thin line. On the facades, marking of window blocks by type W-1, W-2 or WS 12-15, WS15-15 is allowed. The mark of filling the window opening on the elevation put inside the contour of the opening, and for small sizes – under it or on the extension line.

The elevation of the building drawn in the sequence:

- draw a line of ground level and take it out of the contour of the elevation by 30 mm. The slope of the line should correspond to the slope of the planning site. The planning site can be horizontal, and then the soil line will also be horizontal;
- at a distance of 1,5 mm from the first line draw a horizontal thin line - the top line of the blind area;
- thin lines draw horizontal contours of the base, top and bottom of window and doorways, the eaves of the ridge and other parts;
- draw vertical lines of the coordination axes, walls, and window and door openings;

- draw pipes, vertical fences and other elevation details in thin lines;
- put the axes, marks, sizes;
- do the elevation washing;
- make the outline of the elements by a bypass line;
- put down marks, axis marks, legend sizes.

Drawing Foundation of residential building.

In accordance with the 3D design scheme of the building to determine the bearing walls, under which it is need to design the foundations. The material of the foundations must be agreed with the teacher. If the foundation is made of prefabricated reinforced concrete, on the plan of foundations it is necessary to designate the type of applied foundation blocks and bases.

The plane of the foundations depicts the contours and dimensions of the walls foundations with the corresponding bindings to the axes of the building, foundation depth. Depth of foundations is taken depending on the type of soil, construction area, the depth of the soil freezing, natural conditions, presence of the building basement. Conditionally take in soils of medium strength with low levels of groundwater.

The foundations can be: wall footing, located under a wall or in the form of a continuous spread footing under the rows of columns; isolated footing, which are built under individual supports (columns or pillars), under walls; raft (mat) foundation, covers the entire area under the structure forming a monolithic slab in the whole area of the building. Mat foundation is adopted when heavy structures are to be constructed on soft made-up ground. Pile foundation is a kind of deep foundation, is actually a slender column or long cylinder made of materials such as concrete or steel, which are used to support the structure and transmit the load at desired depth by either end bearing or skin friction.

To prevent the flooding of rain and melt water into the substructure parts of the building, footing and foundation make the planning of the surface of the building area, creating the necessary inclination to drain surface water. Around the exterior walls should make a blind area of dense waterproof materials (asphalt, asphalt concrete, etc.).

The blind area width is usually take not less 0,5–1,2 m with a slope of 2–3 %.

Drawing Floor Slabs Plan of a residential building.

During the drawing of the Floor Slabs plan are used the following rules:

- to select the necessary sizes of floor slabs according to the catalog that their whole dimensions are accord to the whole dimensions of the building and the location of the partitions. The joints between the slabs should be provided at the place of the partitions, which makes it possible to rationally make the fastening of the last metal anchors, which fix in the joints;

- the necessary length of floor slabs is taking into account their support on a wall not less than 120 mm - 180 mm;

- in order to develop an floor plan, it is necessary to think over the anchoring system of the floor slabs to the walls and to indicate it in the drawings;

- the number of sizes of floor panels should be provided the minimum;

- the floor slabs are mostly required to accept hollow core;

nominal sizes of floor slabs on width are accepted: 1 200, 1 500, 1 800 cm, in length – 3 600, 3 900, 4 200, 4 500, 4 800, 5 100, 5 400, 5 700, 6 000, 6 300, 6 600 cm, height – 220 cm.

In the process of this drawing, it should be taken into account that the contours of the walls are executed with a thin line (or dashed line) and the panels - thick.

The following elements of building project are being developed:

- plan of foundations with the decomposition of foundation blocks and foundation slabs (scale 1: 100);

- plan of section floors/ceiling structures with detailed design and indicate of all elements of structures, their fixings, anchorage (scale 1: 100).

Drawing Roof Top Plan of a residential building.

The plan of the roof of a low-rise building is denote:

- coordinate axes: bordering, deformation joints, in the places of ledges (shelves) in plan and elevations, along the edges of roof sections with various structural and other features and dimensional bindings of such areas;

- denote of roof slopes: arrows - the direction of slopes, numbers - the size of the slope;

- estimates or schematic cross-section of the roof, indicating the direction and magnitude of the roof slope;

- positions of elements and additions of the roof;

- links to nodes not marked on sections and elevations.

The contours of the roof indicate the outer perimeter, draw on the roof plan hearing windows, cover the outputs of ventilation and smoke channels, the outputs of exhaust pipes and sewers. The roof plan also includes: hips of fractures of roof slopes, ridge locations, grooves and gutters; ventilation pipes, lanterns, deformation joints, grooves and watersheds, funnels of the outer gutter and wall gutters; parapets and railings.

The dimensions of the roof include:

- between modular split axes of the house;

- between the extremes of the house;

- values of the roof overhang;

- areas with different construction and roofing material; elements of metal roof enclosures and fire escape; anchorage and coverage dimensions of ventilation and smoke ducts; sewer risers.

3.3 Technical and economic indicators of the residential buildings.

Technical and economic indicators calculated according to ДБН В.2.2-15:2019 Residential buildings. Main requirements.

The area of the apartments is defined as the sum of the areas of all apartment premises except the loggias, balconies, verandas, terraces, cold storerooms and outside vestibules.

The total area of the apartments is defined as the sum of the areas of all apartment premises (except for the entrance vestibules in one-room houses), built-in wardrobes and summer rooms, calculated with such decreasing coefficients:

- for balconies and terraces – 0,3;
- for loggias – 0,5;
- glazed balconies – 0,8;
- verandas, glazed loggias and cold storerooms – 1,0.

The area of a residential buildings defined as the sum of the areas of the building floors, measured within the inner surfaces of the exterior walls, as well as the areas of balconies and loggias.

The area of staircases, elevators and other mines shall be included in the floor area, taking into account their area at the level of a particular floor.

The area of attics and technical floors and basements is not included in the buildings area.

The size of the premises of dwelling houses is determined by their dimensions, measured between the decorated surfaces of the walls and partitions at the floor level (excluding plinths). To determine the area of the attic room, take into account the area of this room with a sloping ceiling of at least 1.5 m at a slope of 30 ° to the horizon; 1,1 m at 45°; 0,5 m at 60° or more.

At intermediate values, the height is determined by interpolation. The area of the room with a lower height is taken into account in the total area with a factor of 0,7, with the minimum height of the wall should be 1,2 m when the ceiling is inclined; 0,8 m at an inclination from 45° to 60°; not limited to inclination of 60° or more.

The building area is defined as the horizontal cross-sectional area of the exterior enclosure at the plinth level, including the projections. The area under the house, located on the pillars, as well as driveways under the house are included in the building area.

The building volume of a dwelling is defined as the sum of the building volume above ±0,000 (above ground) and below this mark (underground).

The building volume of the aboveground and underground parts of the house is determined within the bounding surfaces with the inclusion of fencing structures, light lanterns, etc., starting from the marking of the clean floor of each part of the house, without taking into account the aisles and spaces under the houses on the supports.

To determine the surface of the above-ground part of the building, the number of floors includes all above-ground floors (including attic, technical and basement), if the top of its overlap is above the average planning mark of the earth not less than 2 m.

With different number of floors in different parts of the house on the slope plot, the surface is determined separately for each part of the house.

The technical floor, located above the upper floor, is not taken into account when determining the surface of the house.

The structure of technical and economic indicators for a dwelling house include:

- a) the area of the plot;
- b) building area;
- c) superficiality;
- d) the number of apartments in the house, including:
 - one-room;
 - two or more rooms;
- e) the area of apartments in the house;
- f) the total area of apartments in the house;
- g) the area of built-in non-residential premises;
- k) the total construction volume of all, including:
 - above the mark $\pm 0,00$;
 - below the mark $\pm 0,00$;

2. To carry out an analysis of the technical and economic indicators of a dwelling house.

REFERENCES

1. Котеньова З. І. Архітектура будівель і споруд : конспект лекцій для студентів за напрямом підготовки «Будівництво» / З. І. Котеньова, Н. В. Мороз – Харків : ХНАМГ, 2011. – 143 с.
2. Методичні рекомендації до виконання курсового проекту та самостійної роботи з дисципліни «Архітектура будівель і споруд» (для студентів 1 курсу прискореного навчання, 2 курсу денної, заочної форми навчання та другого вищого навчання за напрямом підготовки 19 – Архітектура та будівництво, спеціальності 192 – Будівництво та цивільна інженерія) / Харків. нац. ун-т міськ. госп-ва ім. О. М. Бекетова; уклад. : Н. В. Мороз, А. М. Панкєєва. – Харків : ХНУМГ ім. О. М. Бекетова, 2018. – 44 с.
3. ДБН В.2.2-15:2019. Житлові будинки. Основні положення. – Київ: Держбуд України, 2019. – 36 с.
3. ДБН В.2.2-9:2018. Громадські будинки і споруди Основні положення. – Київ : Мінрегіонбуд України, 2019. – 49 с.
4. ДБН В 2.6-220:2017. Покриття будинків і споруд. – Київ : Держкоммістобудування України. 2017. – 59 с.
5. ДБН В.2.1-10:2018. Основи і фундаменти будівель та споруд. Основні положення проектування. – Київ : Мінрегіонбуд України, 2018. – 42 с.
6. ДСТУ Б В.2.6-146:2010 (ГОСТ 23166-99). Блоки віконні. Загальні технічні вимоги. – Київ : Мінрегіонбуд України, 2010. – 106 с.
7. ДБН В.2.2-28:2010. Будинки і споруди. Будинки адміністративного та побутового призначення. – Київ : Мінрегіонбуд України, 2011. – 28 с.
8. Гетун Г. В. Архітектура будівель та споруд : підручник / Г. В. Гетун. – Київ : КОНДОР, 2011. – Книга 1: Основи проектування: – 378 с.

APPENDIX A

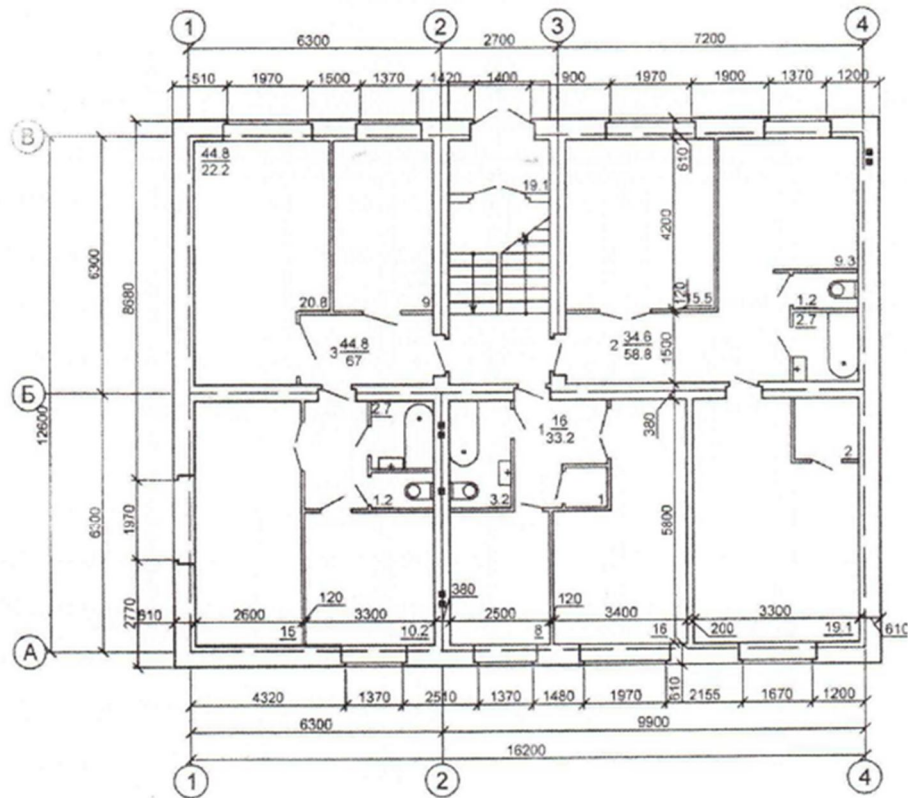

Figure A.1 – Plan of the first floor (Scale 1:100)

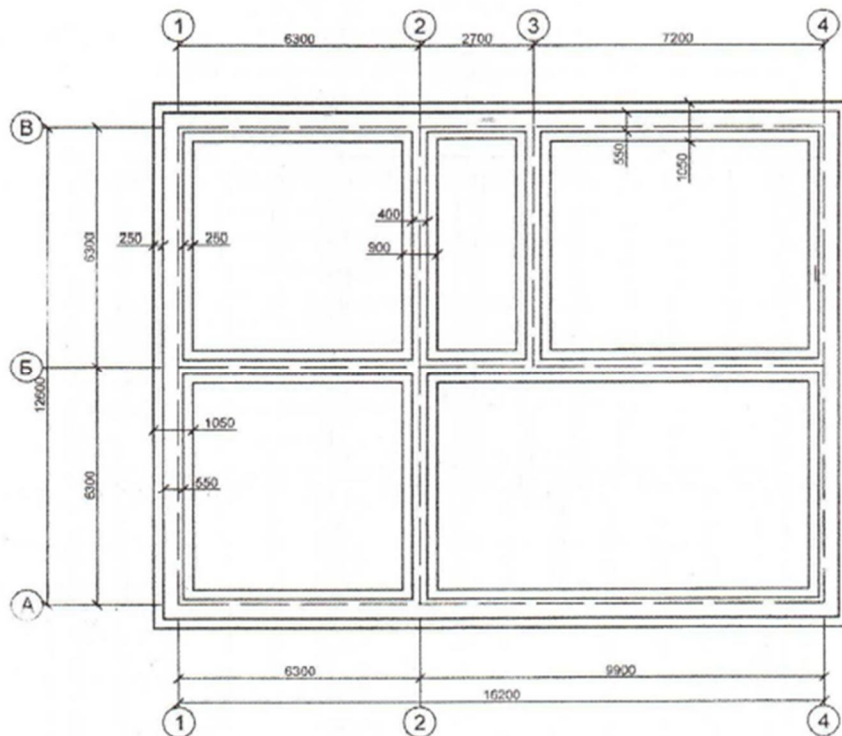

Figure A.2 – Plan of stripe foundation (Scale 1:100)

A - A

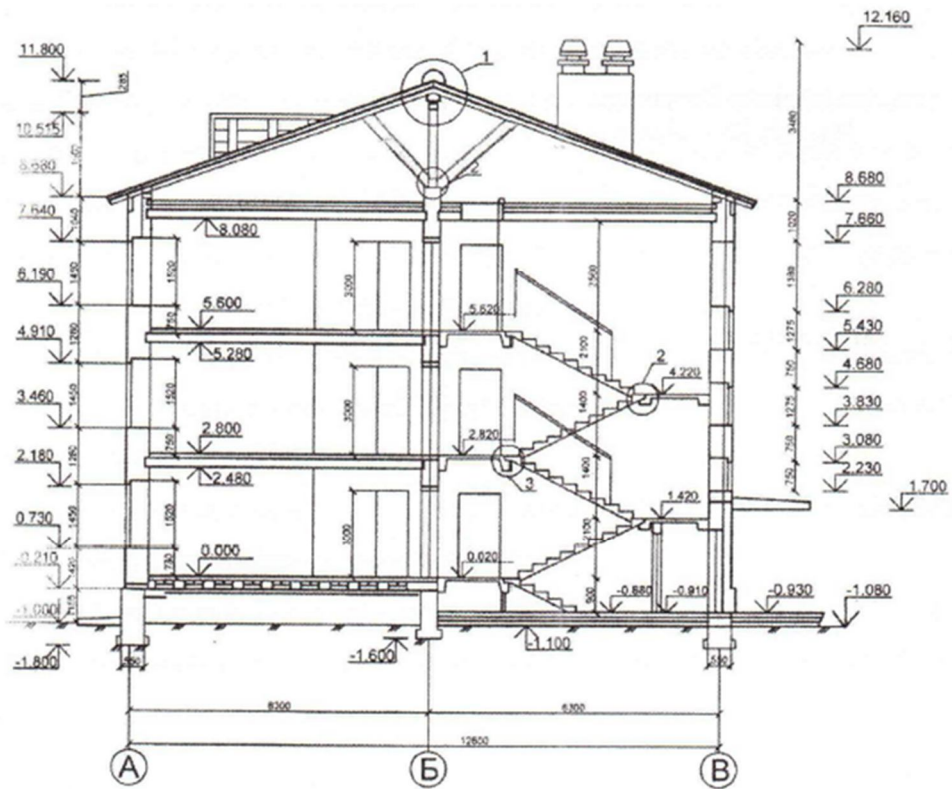

Figure A.3 – Vertical cross-section A-A (Scale 1:100)

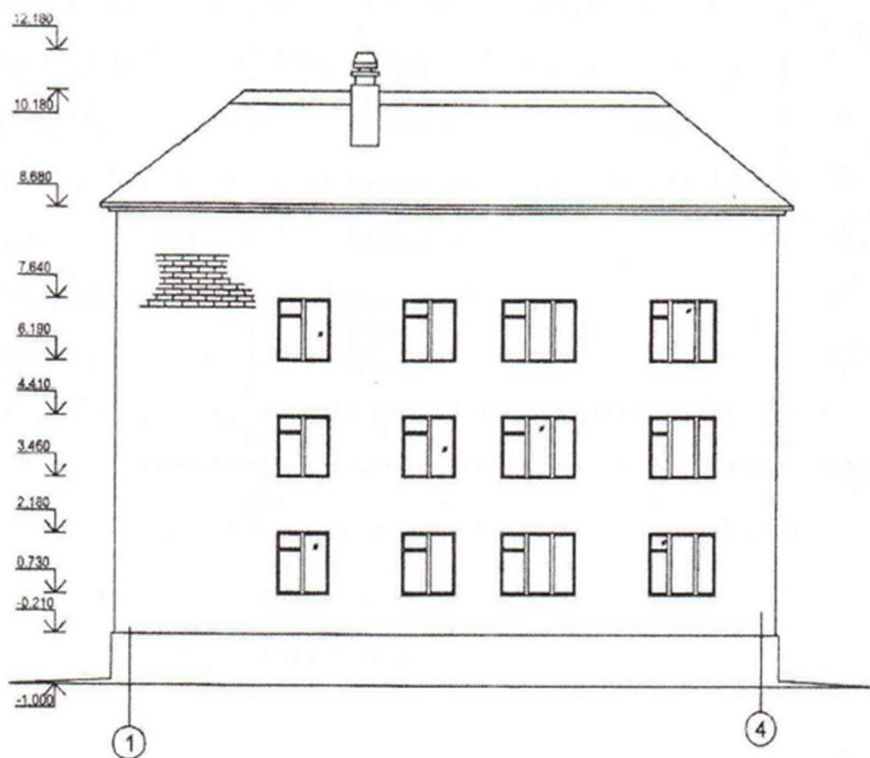

Figure A.4 – Main Elevation (Scale 1:100)

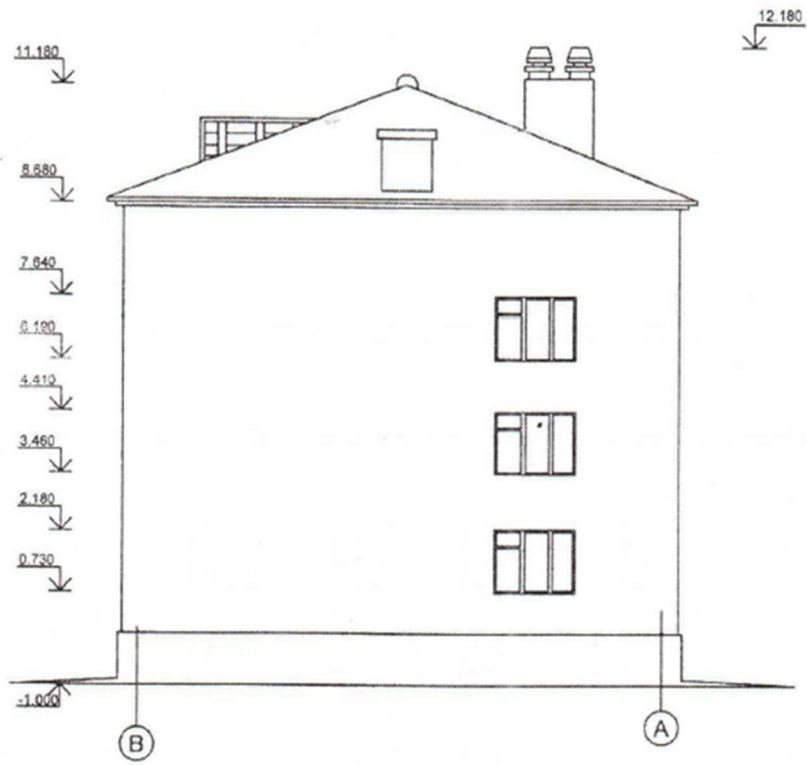

Figure A.5 – Side Elevation (Scale 1:100)

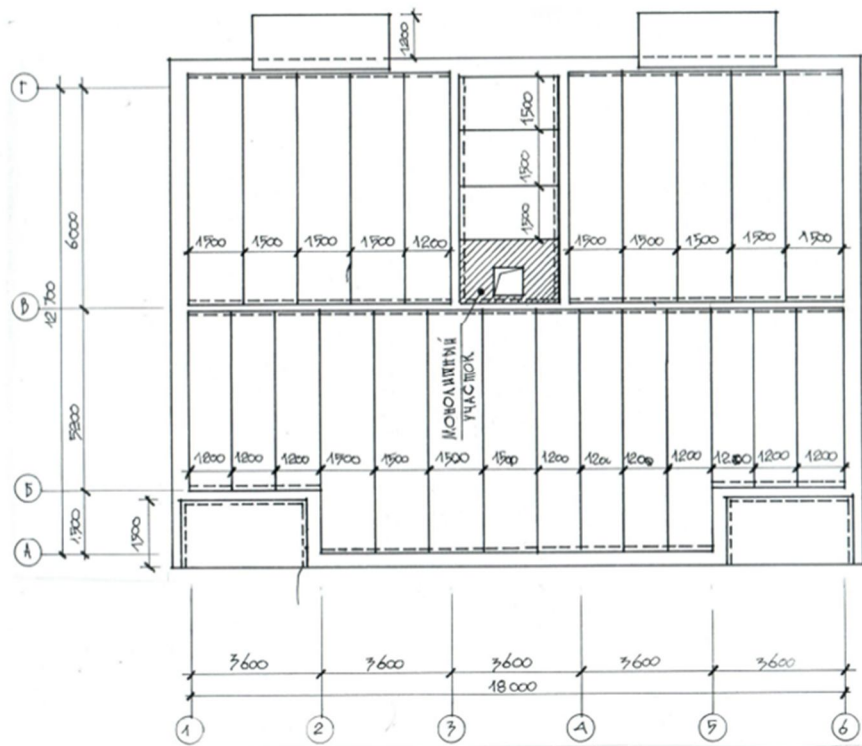

Figure A.6 – Plan of floor slabs (Scale 1:100)

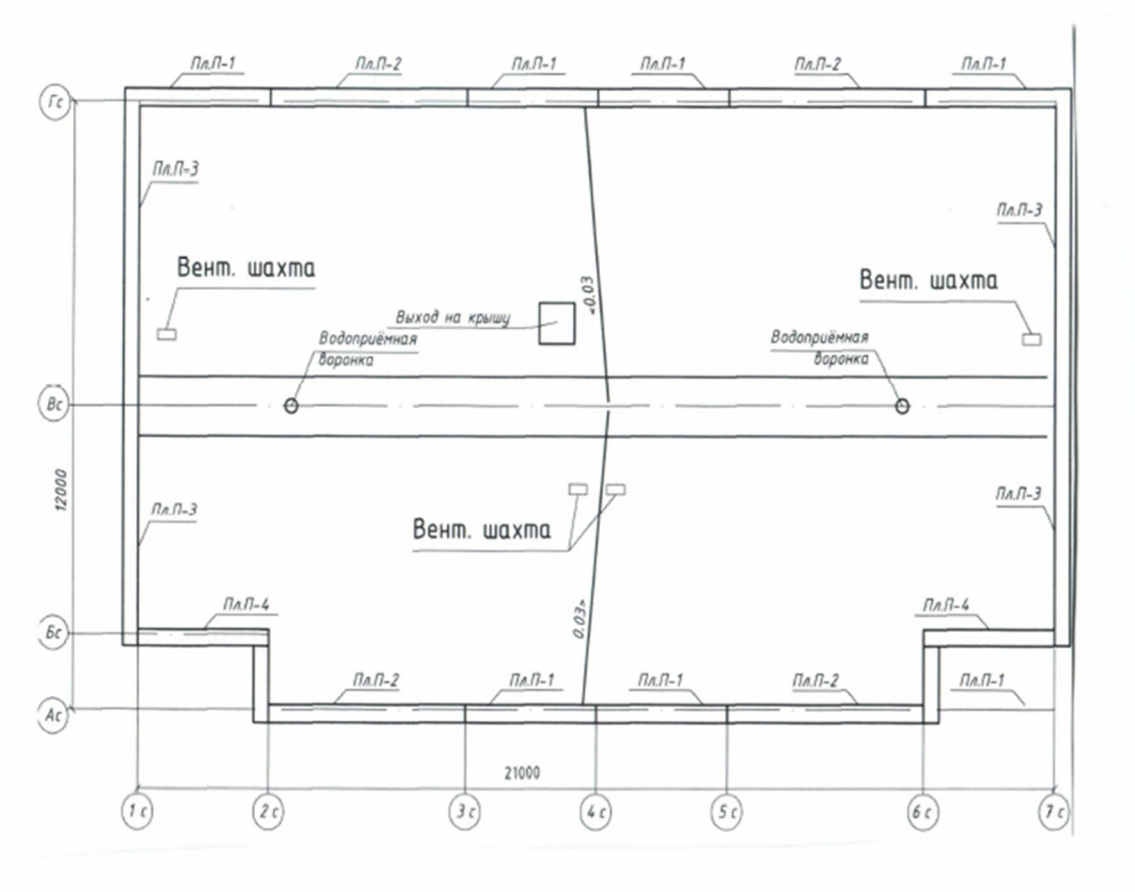

Figure A.7 – Plan of roof (Scale 1:100)

APPENDIX B

Tabl B.1 – Options for constructive solutions

Variant	Wall and Partition	Foundation	Floor	Roof and Roofing	Draining water from the roof	Stair construction
1	Lime-sand brick	Continuous spread footing	Solid floor (slab)	Flat roof	External organized	two metal stringers
2	Clay brick	Traditional strip foundation	Panels	Double pitch with attic	External non-organized	two reinforced concrete stringers
3	Clay brick	Continuous spread footing	Solid floor (slab)	Flat roof	External organized	two reinforced concrete stringers
4	Calcium silicate brick	Piles	Panels	Double pitch with attic	External non-organized	two metal stringers
5	Calcium silicate brick	Continuous spread footing	Panels	Double pitch with attic	External organized	large-scale element

APPENDIX C

Variants for design

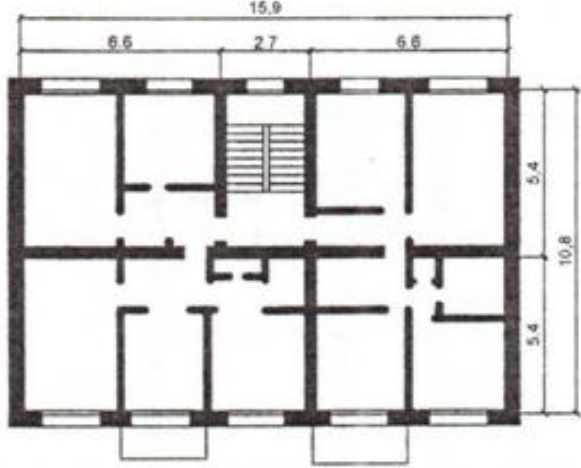
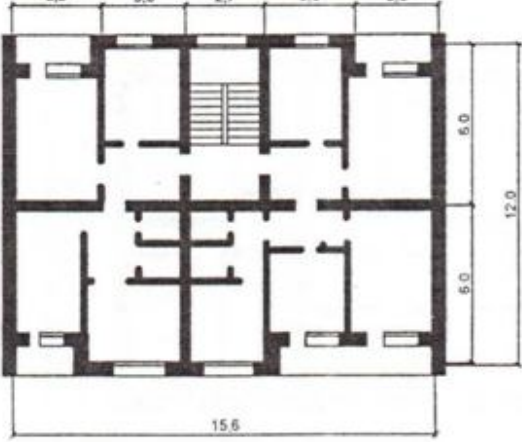
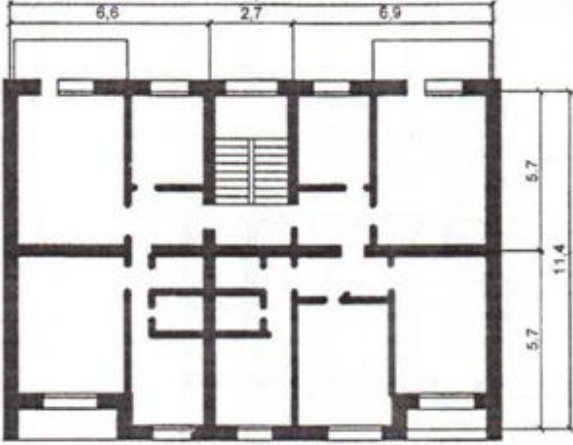
Task number	Scheme of the plane	Number of construction task
<p style="text-align: center;">1</p> <p style="text-align: center;">2</p> <p style="text-align: center;">3</p> <p style="text-align: center;">4</p> <p style="text-align: center;">5</p>		<p style="text-align: center;">1</p> <p style="text-align: center;">2</p> <p style="text-align: center;">3</p> <p style="text-align: center;">4</p> <p style="text-align: center;">5</p>
<p style="text-align: center;">6</p> <p style="text-align: center;">7</p> <p style="text-align: center;">8</p> <p style="text-align: center;">9</p> <p style="text-align: center;">10</p>		<p style="text-align: center;">1</p> <p style="text-align: center;">2</p> <p style="text-align: center;">3</p> <p style="text-align: center;">4</p> <p style="text-align: center;">5</p>
<p style="text-align: center;">11</p> <p style="text-align: center;">12</p> <p style="text-align: center;">13</p> <p style="text-align: center;">14</p> <p style="text-align: center;">15</p>		<p style="text-align: center;">1</p> <p style="text-align: center;">2</p> <p style="text-align: center;">3</p> <p style="text-align: center;">4</p> <p style="text-align: center;">5</p>

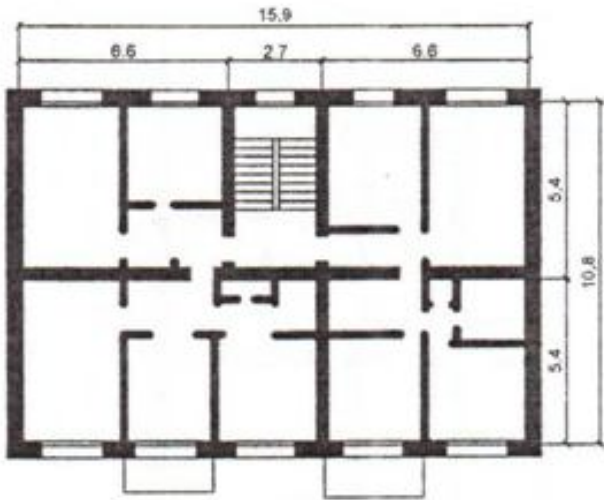
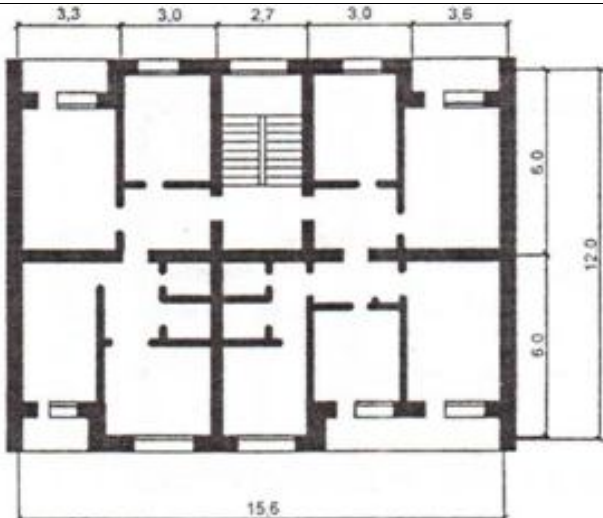
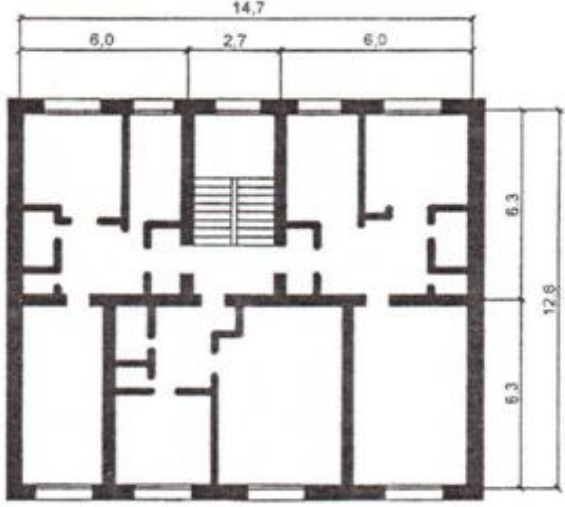
<p>16</p> <p>17</p> <p>18</p> <p>19</p> <p>20</p>		<p>1</p> <p>2</p> <p>3</p> <p>4</p> <p>5</p>
<p>21</p> <p>22</p> <p>23</p> <p>24</p> <p>25</p>		<p>1</p> <p>2</p> <p>3</p> <p>4</p> <p>5</p>
<p>26</p> <p>27</p> <p>28</p> <p>29</p> <p>30</p>		<p>1</p> <p>2</p> <p>3</p> <p>4</p> <p>5</p>

Виробничо-практичне видання

Методичні рекомендації
до виконання курсового проєкту
та самостійної роботи
з навчальної дисципліни

«АРХІТЕКТУРА БУДІВЕЛЬ ТА СПОРУД»

*(для студентів 2 курсу денної форми навчання першого (бакалаврського)
рівня вищої освіти
за спеціальністю 192 – Будівництво та цивільна інженерія)*

(англ. мовою)

Укладачі: **МОРОЗ** Наталія Валеріївна
ГАРБУЗ Алла Олегівна

Відповідальний за випуск *О. О. Надрова*
За авторською редакцією
Комп'ютерне верстання *А. О. Гарбуз*

План 2021, поз. 39 М

Підп. до друку 10.06.2021. Формат 60 × 84/16.
Друк на ризографі Ум. друк. арк. 1,3.
Тираж 50 пр. Зам. №

Видавець і виготовлювач:

Харківський національний університет
міського господарства імені О. М. Бекетова,
вул. Маршала Бажанова, 17, Харків, 61002
Електронна адреса: office@kname.edu.ua
Свідоцтво суб'єкта видавничої справи:
ДК № 5328 від 11.04.2017.