

MINISTRY OF EDUCATION AND SCIENCE OF UKRAINE

**O. M. BEKETOV NATIONAL UNIVERSITY
of URBAN ECONOMY in KHARKIV**

**Methodological guidelines
for practical and independent work
on the subject**

«ARCHITECTURAL MODELING»

(for 4th-year students specialty 191 – Architecture and urban planning)

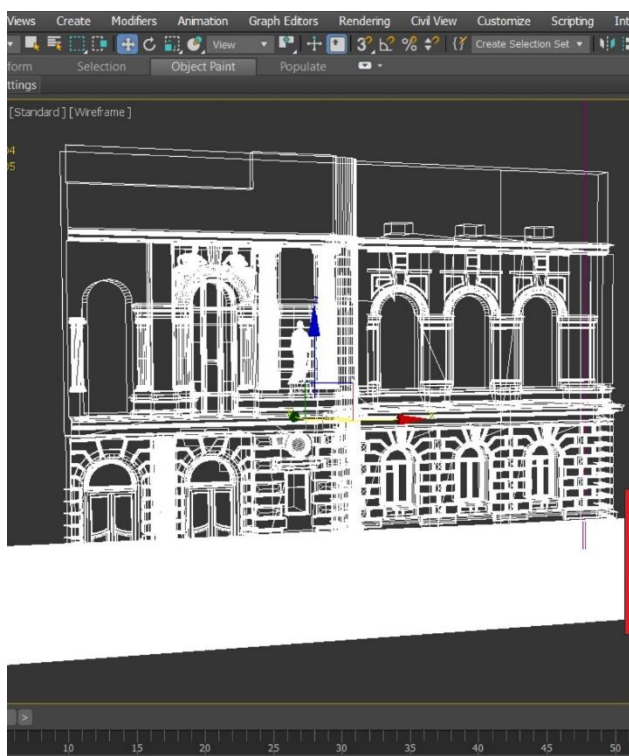

**Kharkiv
O. M. Beketov NUUE
2021**

Methodological guidelines for practical and independent work on the subject «Architectural modeling» (for 4th-year students specialty 191 – Architecture and urban planning) / O. M. Beketov National University of Urban Economy in Kharkiv ; com. : D. Gura, O. Mironenko, Y. Kuznietsova, N. Malik. – Kharkiv : O. M. Beketov NUUE, 2021. – 22 p.

Compilers: D. Gura,
O. Mironenko,
Y. Kuznietsova,
N. Malik

Reviewer PhD in Architectural sciences O. Dudka

Recommended by the department of buildings, structures and design of the architectural environment, record № 7 on 20.01.2021.

CONTENT

Introduction	4
1 General regulations	5
2 Organizational and methodological recommendations	5
3 Topics of practical tasks	5
4 The structure of the educational process and the recommendation to the practical and independent tasks	6
5 The methods of control and the structure of the test credit	9
List of the recommended sources	10
Supplements	11

INTRODUCTION

The course of “Architectural Modeling” is a basic discipline of the subjects cycle training for architecture students at a bachelor level, which is studied four semesters.

The recommendations for organizational and educational issues that may arise in the practical and independent work of students that study discipline “Architectural Modeling” are given briefly in the practical guidance.

The materials are based on the educational standards of the practical training and independent work in accordance with the regulations of the syllabus.

The aim and objectives of the discipline is to form an integrated approach to the task of designing, which includes methods of building software design simulation as well as the methods of traditional instrumental construction. The discipline is based on theoretical and methodological criteria of architectural science, involving historical experience and considering the typological and urban architectural design requirements, knowledge and skills necessary for the development of urban and architectural objects.

The development of the discipline “Architectural Modeling” is necessary on the basis of the professional training of the architects of the future. It is easy to reach the students' knowledge of the additional functions of the three-dimensional software products ArchiCAD and 3dsMax, so that the folding graphic design of the process of memorizing the elements and the three-mode models allows

Study of the discipline "Architectural modeling" includes professional training of future architects to ensure the quality of the software for testing computer technology in architectural design, developing the basic position of testing for 3D programs in professional development. It is easy to reach the students' knowledge of the additional functions of the three-dimensional software products ArchiCAD and 3dsMax, so that the folding graphic design of the process of memorizing the elements and the three-mode models of architectural monument.

The subject of the discipline:

- 1) methods and techniques for modeling architectural objects for additional software products ArchiCAD and 3dsMax;
- 2) creation of the architectural design of any complexity for unique items not available for the design using conventional tools;
- 3) three-dimensional modeling of an architectural monument.

The gained knowledge is consolidated in carrying out of practical training according to the syllabus (60 hours). The purpose of the independent work (75 hours) is to consolidate the students’ questions that are examined in a classroom; to work independently on practical tasks using the recommended literature sources; to learn how to cope with the additional tools of the program; to solve complex problems while performing the practical training.

1 GENERAL REGULATIONS

The quantitative and thematic time distribution on the practical and independent work is determined by the informative structure of the content module 3 «The design of elements and a three-dimensional model of an architectural monument» – 2,5 credits/90 hours.

Topic 5. The basic principles of three-dimensional objects

1,25/45 credits/hours

1. The methods of drawing and editing three-dimensional objects.
2. Using of the library elements and plugins.

Topic 6. The visualization of the three-dimensional objects of architectural monument

1,25/45 credits/hours

1. The photo-image creation of an architectural monument.

The organization of the students' practical and independent work must create terms for the stage-by-stage mastering of knowledge, abilities, and the methods of development of the project documentation, with using Graphisoft software – ArchiCAD and Autodesk – 3dsMax, independently and under the guidance of a teacher (within the limits of the practical work).

2 ORGANIZATIONAL AND METHODOLOGICAL GUIDANCE

The method of study of the content module 3 “The design of elements and a three-dimensional model of an architectural monument” foresees the classes (60 hours of practical work) with the independent work (75 hours). The “Architectural design” syllabus of the content module 3 “The design of elements and three-dimensional model of an architectural monument” comprises the fulfillment of 4 practical tasks. These practical works are evaluated on two meaningful modules:

1. Modeling of elements and three-dimensional model of an architectural monument.
2. Modeling of an architectural ensemble by means of ArchiCAD.

3 THE TOPICS OF PRACTICAL TASKS OF THE MODULE

Module 1

Practical work № 1. Methods study of construction of architectural profiles. Create a complex profile using the profile manager.

Practical work № 2. Methods study of construction of the windows. Create a creating an edited GDL– object (windows).

Practical work № 3. Methods study construction of the stairs and their allocation on the working drawings.

Module 2

Practical work № 4. Creating a photo-image of an architectural monument.

Examples of graphic practical work s are given at the end of these methodical recommendations in supplements A–D.

The section is given as the structurally semantic table, which includes the information about the maintenance, structure and hour distribution of the separate topics of the practical tasks for students to better understand the educational process, the structure and the connection of the separate elements of the independent tasks with practical classes.

4 THE STRUCTURE OF THE EDUCATIONAL PROCESS AND THE RECOMMENDATION TO THE PRACTICAL AND INDEPENDENT TASKS

The discipline “Architectural modeling” involves practical and independent work of the student on certain topics (Table 1), which allow students to develop skills and abilities of practical application of theoretical provisions of the discipline in their practical work.

Table 1 – Structure of the organization and the content of practical classes

Types of training sessions	Hours	Topics and work content
1	2	3
Topic 5. The basic principles of three-dimensional objects		
Practical work № 1	6	<i>Methods study of construction of architectural profiles.</i> Your computer and software are being prepared and set up for use. We gradually and thoroughly get acquainted with the program Grafisoft interface, namely, we recall the basic components and consider new product features. The emphasis in mastering this topic is to study the function of the individual complex “Profile Manager”, the correct preservation of drawings and 3D-documentation.

Sequel of the table 1

1	2	3
Individual work	10	<p><i>Construction of architectural profiles.</i> Students create individual drawings by themselves, using the version issued by teachers, consolidating acquired skills. Simulate a 3D element using a tool – complex “Profile Manager” and apply it on the vertical surface of the wall, which creates a general shape of the profile. The final stage is the graphic design of sheets with practical work on formats A4 (2 sheets of vertical orientation) or A3 (1 sheets of horizontal orientation).</p>
Practical work № 2	6	<p><i>Methods study of construction of the windows.</i> First off all we analysis difficult forms of windows, which can be used in architectural objects. Teachers give each of student an individual version of the shape of window facade. We remind student about previously studied tool “ceiling” and we study features of using manager ID elements as an auxiliary modifier in modeling.</p>
Individual work	15	<p><i>Construction of windows.</i> Independent work for the student is modeling an individual window. The latter is performed using the tool “ceiling” in several stages. The first one – in one of the ceiling is prescribed ID word “Wallhole” in order to save in GDL-object. The second one – a wall is created, on this wall in feature we apply a complex window as an object. After which we carry out the graphic design of the practical assignment in formats A4 (2 sheets of vertical orientation) or A3 (1 sheets of horizontal orientation).</p>

Sequel of the table 1

1	2	3
Practical work № 3	18	<p><i>Methods study construction of the stairs and their allocation on the working drawings.</i></p> <p>In the classes study different approaches to building stairs in 3D-programs. Possible difficulties in volume construction and ways to solve them are analyzed. The construction of drawings stairs is considered in detail: plan, section, facade (depending on the selected type of stairs). Attention is paid to the professional design of drawings according to the basic requirements for design and working documentation. The main volume of the stairs is created and the main directions for rendering are set (the process of converting a 3D model into an image – jpg).</p>
Individual work	20	<p><i>Construction of stairs and their design on working drawings.</i> The student independently analyzes the analogues of the stairs in the interior. Selects and modifies the main volume of stairs according to their needs and decides what the overall interior of the room will be. Performs interior space modeling with emphasis on the stairs. Conducts the layout of working drawings and coordinates it with teachers. Possible options for layout drawings on formats A4 (2 sheets of vertical orientation) или A3 (1 sheets of horizontal orientation).</p>
Topic 6. The visualization of the three-dimensional objects of architectural monument		
Practical work № 4	30	<p><i>Creating a graphic album for the selected architectural building.</i> At the lessons analyze objects of architectural heritage. Each student chooses a building according to their own preferences, processes it outgoing materials</p>

Conclusion of the table 1

1	2	3
		(historical, urban planning, planning, constructive) and creates drawings. After selecting the object, we move on to the level of modeling with help of computer programs. In the presence of complex curvilinear details we use and improve knowledge of methods of construction of profiles (by analogy with the 1 st practical task).
Individual work	30	<i>Creating a photo of an architectural monument model. The student independently improves the total volume 3D models. Textures the model and renders it. Creates drawings according to the processed source materials then composes all components on formats A3 (see supplements E).</i>

5 THE METHODS OF CONTROL AND THE STRUCTURE OF THE TEST CREDIT

The following forms of current control (see table 2) of knowledge for the content module 3 are provided:

- 1) performing graphic exercises – practical work independently and in the classroom;
- 2) control measurement of knowledge in the form of a survey, the answer to which the student submits in the form of a graphic image in a three-dimensional program, as well as the implementation of clauses, which corresponds to practical work in the discipline.

Table 2 – Forms of current control

Types and means of control (testing, control works, individual tasks, etc.)	Distribution of points, %
Current control over the content module 3	
Topic 5. Clausura № 1. Practical work	15 % 20 %
Topic 6. Clausura № 2. Practical work	15 % 20 %
Final control over the content module 3 – <i>differential test</i>	30 %
Total for the content module 3	100 %

LIST OF THE RECOMMENDED SOURCES

Basic

1. Иванова О. Практикум по ArchiCAD: 30 актуальных проектов : практикум / О. Иванова. – СПб : БХВ-Петербург, 2011. – 368 с.
2. Горелик А. Самоучитель 3ds Max 2020 / А. Горелик. – СПб : БХВ-Петербург, 2021. – 544 с.
3. Миловская О. С. 3ds Max 2018 и 2019. Дизайн интерьеров и архитектуры / О. С. Миловская. – Санкт-Петербург : Питер Пресс, 2019. – 416 с.
4. Кулагин Б. Ю. 3ds Max в дизайне среды / Б. Ю. Кулагин, О. Г. Яцюк. – Санкт-Петербург : БХВ – ИК, 2008. – 973 с.
5. Ким Ли. 3D Studio MAX для дизайнера. Искусство трехмерной анимации / Ли Ким и др. – Киев : ТИД «ДС», 2003. – 864 с.
6. Справочное руководство ArchiCAD 16 / Graphisoft. – Будапешт : Graphisoft, 2012. – 900 с.
7. Справочное руководство GDL / Graphisoft. – Будапешт : Graphisoft, 2015. – 340 с.
8. ArchiCAD 16 руководство по проведению расчетов / Graphisoft. – Будапешт : Graphisoft, 2012. – 90 с.
9. top-videokurs.net [Electronic resource]. – Regime of access: <http://www.top-videokurs.net/proektirovanie/videokurs-modelirovat-v-archicad-14-legko.html>, free (date of the application: 11.02.2021). – Header from the screen.
10. render.camp [Электронный ресурс]. – Режим доступа: <https://www.youtube.com/channel/UCvGtqwrsnmX4csg59vT1aZg>, свободный (дата обращения: 28.01.2021). – Название с экрана.

Secondary

11. ДСТУ Б А.2.4-4-99. Основні вимоги до проектної та робочої документації (ГОСТ 21.101-97). – Чинний від 1997-12-10. – Київ : Держспоживстандарт України, 1999. – 79 с. – (Національний стандарт України).
12. ДСТУ Б А.2.4-6-95. Правила виконання робочей документації генеральних планів підприємств, споруджень і житлово-громадських об'єктів (ГОСТ 21.508-93). – Чинний від 1993-11-10. – Київ : Держспоживстандарт України, 1996. – 45 с. – (Національний стандарт України).
13. ДСТУ Б А.2.4-2-95. Умовні графічні позначення і зображення елементів генеральних планів та споруд транспорту (ГОСТ 21.204-93). – Чинний від 1993-11-10. – Київ : Держспоживстандарт України, 1997. – 34 с. – (Національний стандарт України).

SUPPLEMENT A
Album cover to the content module № 1



MINISTRY OF EDUCATION AND SCIENCE OF
UKRAINE
O. M. BEKETOV NATIONAL UNIVERSITY
of URBAN ECONOMY in KHARKIV
department BS and DAE

ALBUM

for the practical work on the course:
«Architectural Modeling»

Content module № 1
«MODELING OF ELEMENTS AND
THREE-DIMENSIONAL MODEL
OF AN ARCHITECTURAL MONUMENT»

Developed by: st. gr. A 2016-4
Kirilenko V. Ya.
Checked by: Gura D. M.,
Kuznietsova Y. Ya.

KHARKIV 2020

Drawing A.1 – Example of the cover of the album to practical works 1-3

SUPPLEMENT B
Profile drawings with dimensions

Practical work № 1. Methods study of construction of architectural profiles.
Create a complex profile using the profile manager

Profile of an architectural element with size

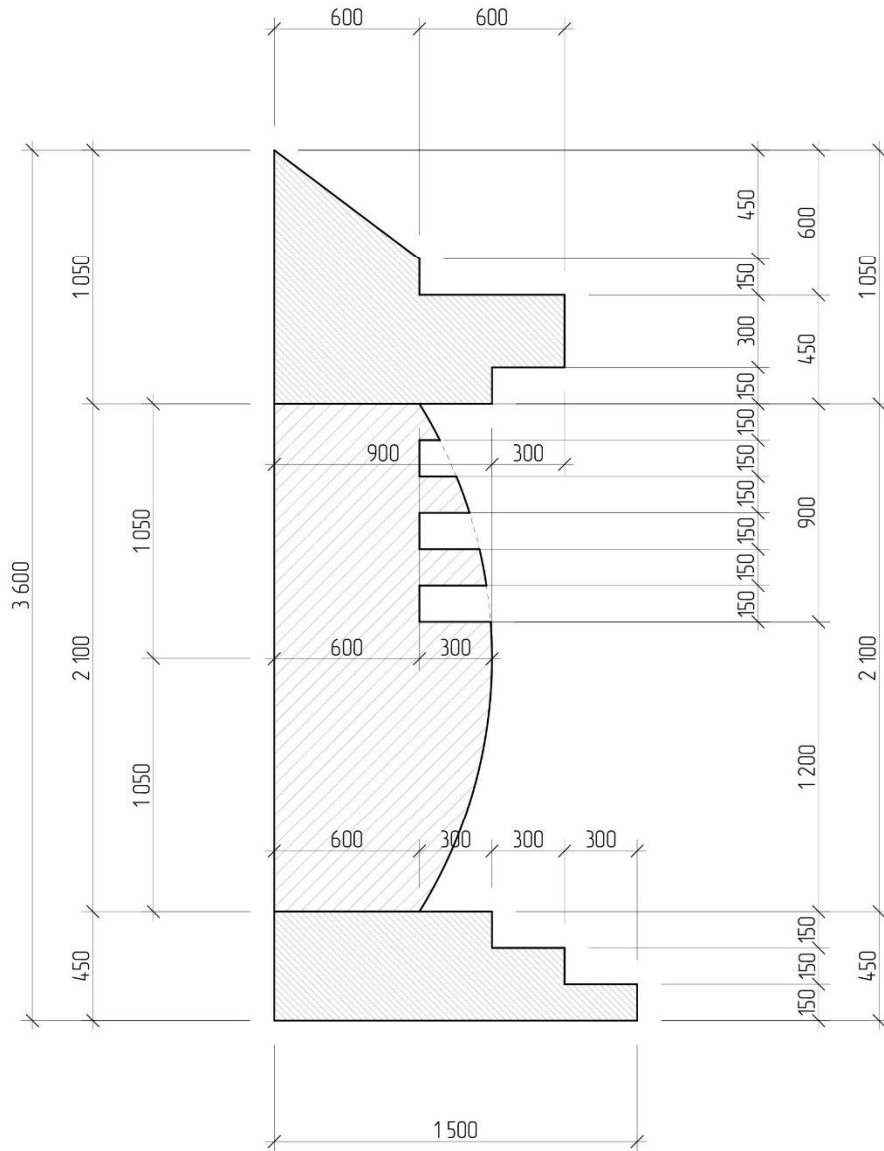

Position	F. N.	Signature	Date	<i>Ministry of Education and Science of Ukraine</i>		<i>NUUE</i>
Developed by	Babenko K. V.			Practical work № 1 (option 1)		Group
Checked by	Gura D. M.					
Checked by	Kuznietsova Y.			Paper 1	Paper's 2	A 2016-4

Drawing B.1 – An example of the first part of a practical task № 1

3D- model of architectural element

Practical work № 1. Methods study of construction of architectural profiles.
Create a complex profile using the profile manager

General form

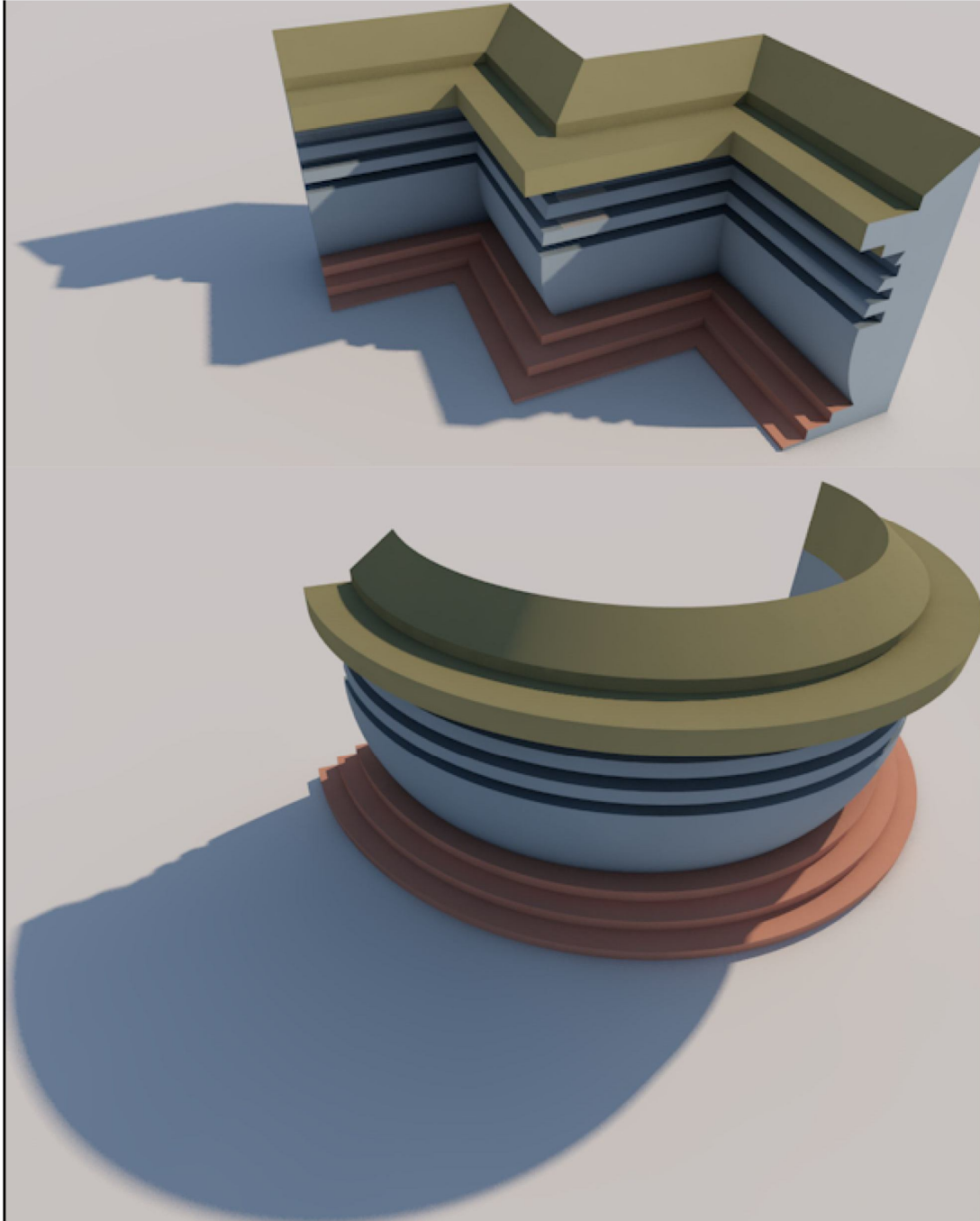

Position	F. N.	Signature	Date	<i>Ministry of Education and Science of Ukraine</i>	<i>NUUE</i>
Developed by	Babenko K. V.			Practical work № 1 (option 1)	<i>Group</i>
Checked by	Gura D. M.				
Checked by	Kuznietsova Y.			Paper 2	Paper's 2
					A 2016-4

Drawing B.2 – An example of the second part of the practical task № 1

SUPPLEMENT C
Drawings of the window with the sizes

Practical work № 2. Methods study of construction of the windows.
 Create a creating an edited GDL– object (windows).

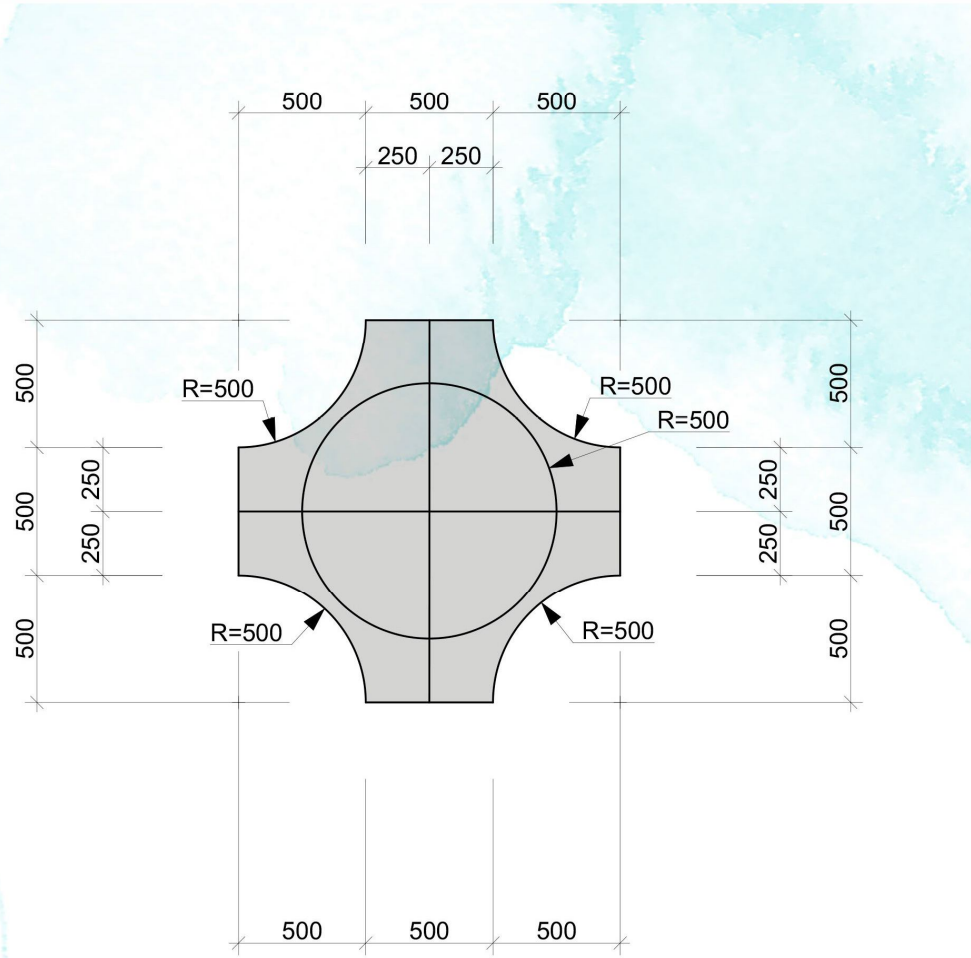

План

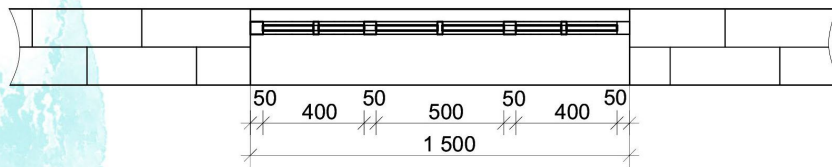

Position	F. N.	Signature	Date	Ministry of Education and Science of Ukraine		NUUE
Developed by	Nos A. I.			Practical work № 2 (option 10)		Group
Checked by	Malik N. O.					
Checked by	Muronenko O.			Paper 1	Paper's 2	A 2017-3

Drawing C.1 – An example of the first part of a practical task № 2

3D-window model

Practical work № 2. Methods study of construction of the windows.
Create a creating an edited GDL– object (windows).

General view

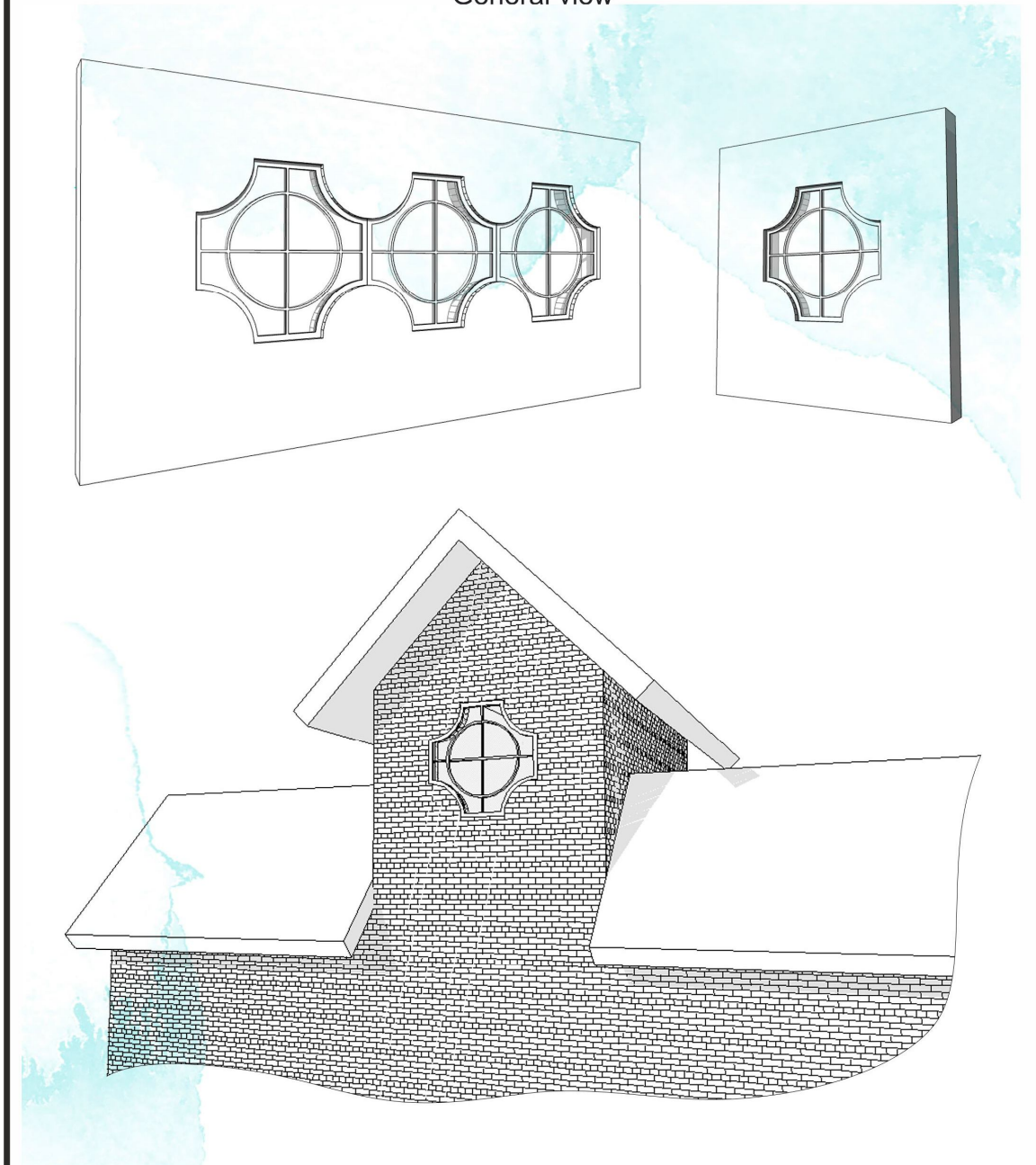

Position	F. N.	Signature	Date	<i>Ministry of Education and Science of Ukraine</i>	<i>NUUE</i>
Developed by	Nos A. I.			Practical work № 2 (option 10)	Group
Checked by	Malik N. O.				
Checked by	Muronenko O.			Paper 2	Paper's 2
					A 2017-3

Drawing C.2 – An example of the second part of the practical task № 2

SUPPLEMENT D
Architectural solution of stairs

Practical work № 3.

Methods study construction of the stairs and their allocation on the working drawings
Example of the stairs

The plan is on the mark +3.000
M 1:50

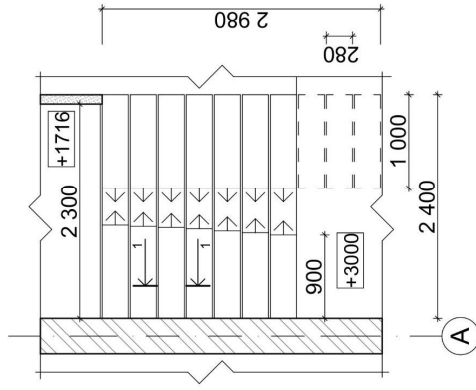

Fragment of the facade
M 1:50

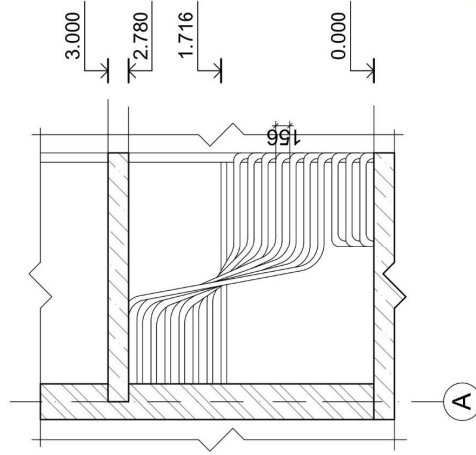

Incision 1-1
M 1:5

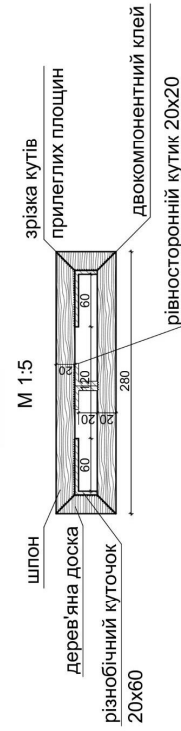

Position	F. N.	Signature	Date
Developed by	Ribalchenko E		
Checked by	Gura D. M.		
Checked by	Kuznietsova Y.		

Ministry of Education and Science of Ukraine		NUUE
Practical work № 1 (option 1)		Group
Paper 1	Paper's 1	A 2016-4

SUPPLEMENT E

An example of designing an album of practical tasks on the content module № 2



Sheets of paper № 1- Historical background



Established in 1886 as Kharkiv Public Library. The founders of the library were: A. Ruhr, Professor A. Kirpichnikov, M.F. Sumtsov and others. Library kept on donations and charge readers for using books.

In the first year of operation of the library in the three wing of Nicholas Square (now Square, Constitution) readers served by five employees, the fund totaled 1 700 copies of publications. It published "The first public library catalog Kharkiv (H., 1886.-89s.). These directories published in 1913.

1889 – A format-serial arrangement of fund, which is used now.

1890 – on the outskirts of the city created the branch libraries for the workers.

1896 – In the tenth year of existence, the library fund totaled 41.6 thousand copies. Basis dokumentozabezpechennyya were donations. "During the first ten years of 2 000 individuals and institutions received 39 806 volumes ... The average postupato 4 000 volumes per year (Bagaley DI, Miller DP history of Kharkiv on 250 years of its existence (1665–1905). V2. – H., 1993. – S.754). Daruvvalyysya separate edition and library goals. Particularly well-known Russian writer GP Danilevskim (over 3 thousand copies.). A prominent lawyer KN Annenkov (1.7 thousand copies.). Doctor VI Pora-Kosice (1.8 thousand copies.). The bulk of the collections from their own libraries gave also known philologist-slovist OO Potebnyia, Professor V. Dobrotvorskyy, PI Sokal, writer I. Aksakov, and many other important personalities.

1898 – started a general alphabetical directory for the Prussian system of book description.

1901 – Moving to a new building (now Lane. Korolenko, 18). The building made architect OM Beketov. He was a member of the board of the library and got for his development of the honorary title of academician of architecture. Started issuing readers free subscribers (teachers in primary schools and colleges, students, exchange students and others. Category).

1903 – became the first public library opens knyhozobiren country music department (for example the Paris Library) , Department of Manuscripts and autographs (at the initiative of chairman DI Bahaliya), Department Yudaica, which focuses on Jewish literature. Bezpresydenntnym phenomenon was the discovery of library (on the initiative of LB Havkinyoi). Formed a unique content of document library fund. Becomes more active work to identify, study and promotion of best library experience, including foreign, expand international relations. HNB foreign partners are renowned library institutions and organizations of the United States (Library of Congress, the New York Public Library, the library of New York at Albany, the Public Library in Manchester Public Library. Krera in Chicago), Great Britain (British Library, library offices in London, Klerkenskiva Library), France (National Library in Paris), the International Bibliographic Institute in Bryuselli and libraries in Germany, Austria, Japan and other countries.

1904 – The third from the entrance of Russian workers with technical and vocational education (St. Petersburg, January) spivpratsivnytsya library LB Havkina advance library education project.

1905 – The Library took part in the World Exhibition in Liège (Belgium) and was awarded an honorary diploma.

1904) won a gold medal.

1906 – At the initiative of the Library Board GM DI Abramov and Bahaliya opens the Ukrainian team. He had no analogs in the whole country. Among the main activities of the Ukrainian commission, which guided his work have been to provide funds for acquisition of publications about the history, economy, and culture of Ukraine, works of Ukrainian writers, regional instruments bibliografuvannya these materials and so on. In different years within the Ukrainian commission were M. Mikhnovskyy, first chairman, passionate warriors for the national idea, the author of a popular political treatise "Independent Ukraine". D. Bagaley, H. Alchevsk, S. Dremtsov, G. Gabala known writer Mr. . Holkevich, who was chairman of the commission in 1914, and other famous figures of Ukrainian culture.

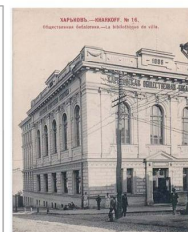

International relations

The library has extensive international links. The partners HDNB – Library of Congress, National Library of Bulgaria, Poland, Portugal, Turkey, Cuba, the library of the University of Sapporo (Japan), Sofia (Bulgaria), Lublin and Poznan (Poland), Austrian Institute for the southern and south-eastern Slavs Yang (Vienna), the Goethe Institute (Munich, Germany), Institute of Electrical and electronics engineers (USA), US-Ukrainian Foundation "Saber-Light", International Renaissance Foundation, Friends of Ukraine (Canada), etc. When the department of literature in foreign languages open the Austrian Library, the German reading room and library, the Council of Europe on Human Rights at the Department Ukrainika – Ukrainian-Canadian library with scientific-methodical department, an office library.



Drawing E.1 – Album cover and historical background

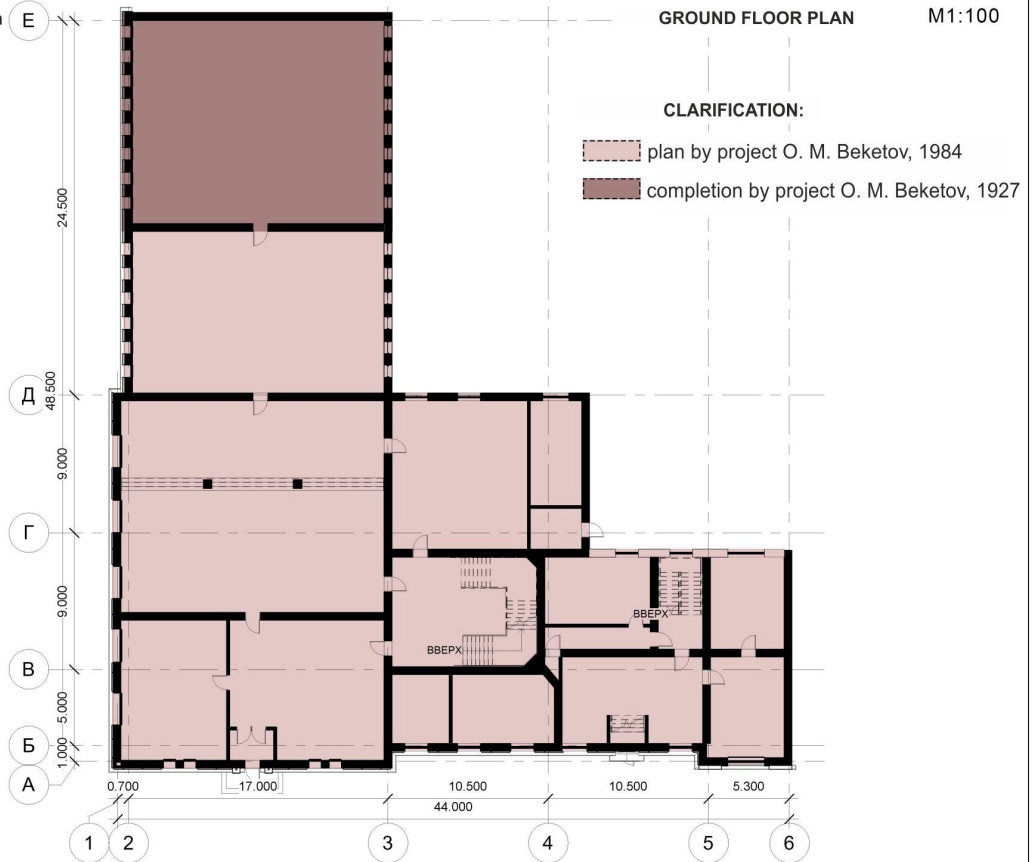
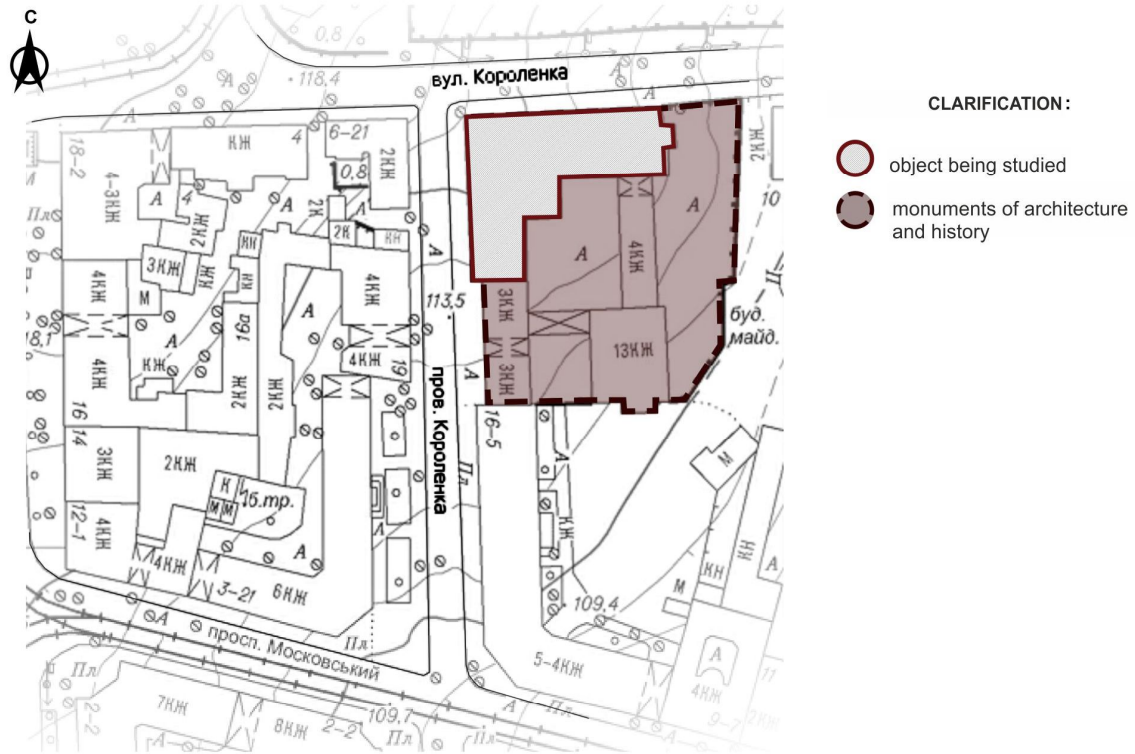

Drawing E.2 – Scheme of the general plan and the plan of the first floor

Sheets of paper № 3- The roof plan

M1:100

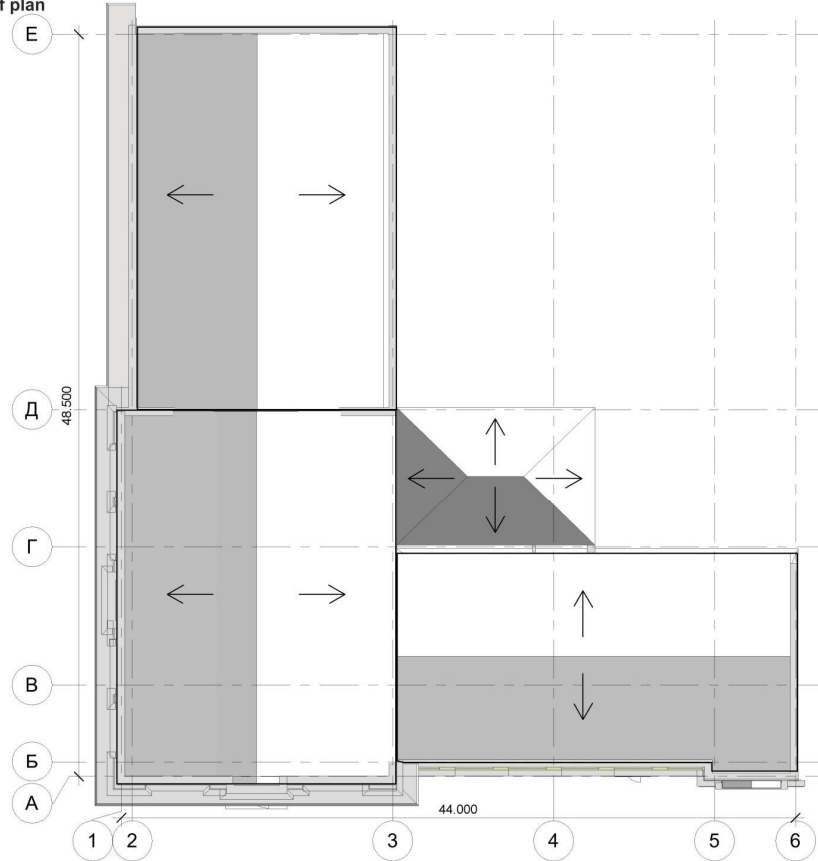

Sheets of paper № 5- Facades

FASADE 1-6 M1:100



FASADE E-A M1:100

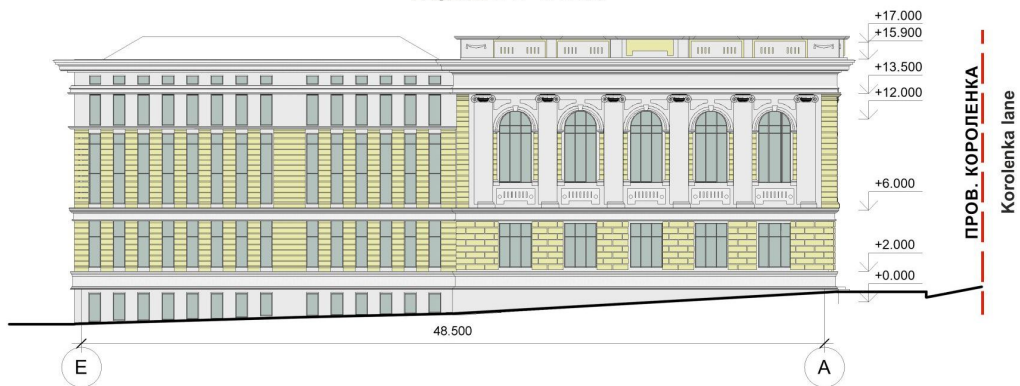

Drawing E.3 – Roof plan and facades

Sheets of paper № 6 - Visualization



Sheets of paper № 7 - Photofixation



Drawing E.4 – Visualization and photofixation

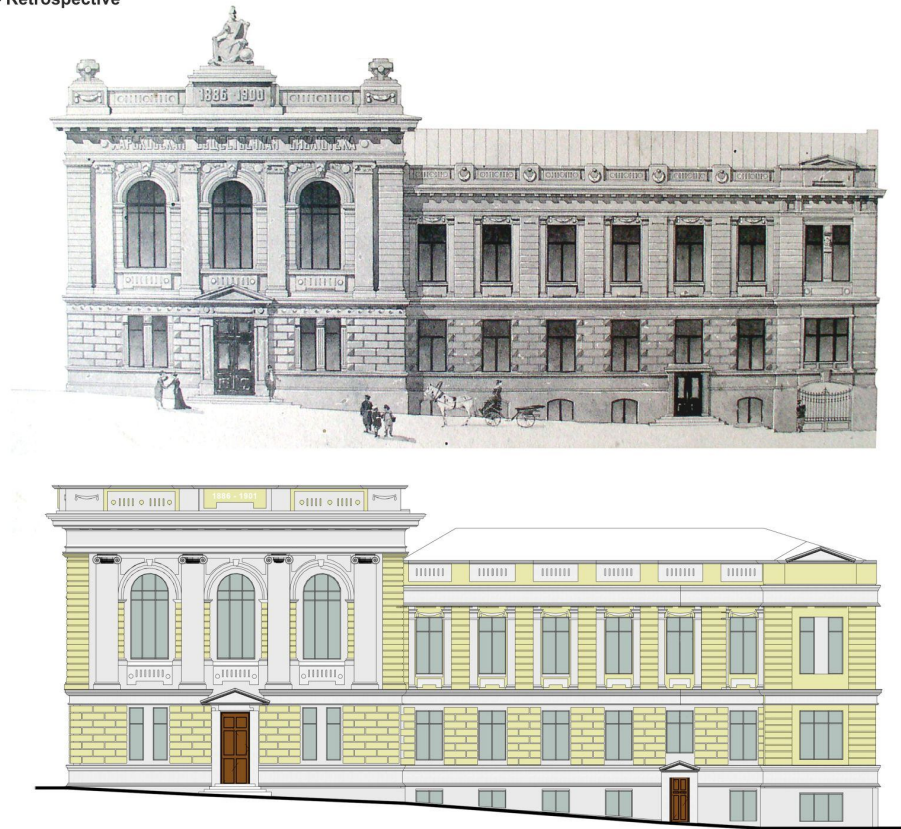

Drawing E.5 – Retrospective

The album of practical tasks in the discipline “Architectural Modeling” was made by a 4th year student A. R. Vlasko, 2020.

Work managers PhD in architecture Y. Yu. Kuznietsova and senior lecturer D. M. Gura

Виробничо-практичне видання

Методичні рекомендації
до практичних занять та самостійної роботи
з навчальної дисципліни

«АРХІТЕКТУРНЕ МОДЕЛЮВАННЯ»

*(для іноземних студентів 4 курсу
спеціальності 191 – Архітектура та містобудування)*

(Англ. мовою)

Укладачі: **ГУРА** Денис Миколайович,
МИРОНЕНКО Олег Вікторович,
КУЗНЄЦОВА Яна Юріївна,
МАЛІК Наталія Олексіївна

Відповідальний за випуск *О. А. Попова*
Технічний редактор *О. А. Норик*
Комп'ютерне верстання *Я. Ю. Кузнєцова*

План 2021, поз. 476 М

Підп. до друку 16.03.2021. Формат 60 × 84/16
Друк на ризографі. Ум. друк. арк. 1,3.
Тираж 50 пр. Зам. №

Видавець і виготовлювач:
Харківський національний університет
міського господарства імені О. М. Бекетова,
вул. Маршала Бажанова, 17, Харків, 61002.
Електронна адреса: rectorat@kname.edu.ua
Свідоцтво суб'єкта видавничої справи:
ДК 5328 від 11.04.2017.